



**PARKS CANADA AGENCY  
Quebec Navigational Waterways  
SIR GEORGE-ÉTIENNE CARTIER  
PEDESTRIAN BRIDGE REHABILITATION  
2016-2017  
V/REF. : CLAC-IIF-899-1510-PPSD**

**TECHNICAL SPECIFICATIONS  
(For Tender)**

**PROJECT N° : 151-03113-02  
DATE : November 23 2016**

Prepared by :

A handwritten signature in blue ink, appearing to be "Hubert Péloquin", written over a horizontal line.

Hubert Péloquin, junior eng., M. Ing

Verified and  
approved by :

\_\_\_\_\_  
David Folcher, eng., M. Sc.

\_\_\_\_\_  
Tony Mailhot, eng., M. Sc.



PARKS CANADA AGENCY (PCA)

SIR GEORGE-ÉTIENNE CARTIER PEDESTRIAN BRIDGE  
REHABILITATION WORKS  
2016-2017  
LACHINE CANAL

V/REF: CLAC-IIF-899-1510-PPSD

**General requirements**

- Section 01005 General instructions
- Section 01110 Summary of works
- Section 01290 Payment procedures
- Section 01340 Shop drawings, product and sample descriptions
- Section 01410 Testing laboratory services
- Section 01500 Site installation and provisional measures
- Section 01545 Security measures
- Section 01561 Environmental protection
- Section 01600 Materials and equipment
- Section 01710 Cleaning
- Section 01720 Document submittal

**Technical requirements**

- Section 02222 Structure – Demolition works
- Section 03100 Concrete forming and accessories
- Section 03200 Concrete reinforcing
- Section 03300 Cast-in-place concrete
- Section 03301 Bridge deck concrete
- Section 05123 Structural Steel For Bridges
- Section 09971 Civil engineering steel structure surface coating

**Appendix**

- Appendix 1 Additional documents - Sir George-Étienne Cartier Pedestrian Bridge construction plans



**PART 1 - GENERAL****1.1 Use of terms**

- .1 « Engineer » refers to the Parks Canada Representative or his (her) authorized representative.
- .2 « Contractor » refers the company chosen to accomplish, in full, all work described herein, according to the standards, specifications and drawings provided for this purpose.
- .3 The specifications and the « A » plan indicated in the tender documents, refer to the specifications and engineering drawings mentioned in the attached index, as well as any drawings subsequently sent related to the same structure.

**1.2 Interpretation**

- .1 Words, expressions and abbreviations with known technical or professional meaning, shall be understood in that sense in the present specifications and present drawings.
- .2 The dimensions shown on the drawings or brought or represented by a module or lines, arrows or otherwise, shall have priority in the drawings.
- .3 Priority is given to the drawings to larger scales. Similarly, the applicable specifications and drawings are always the most recent ones.
- .4 When there is no match between the numerical dimensions shown in the drawings, one shall refer to the Engineer in order to know the applicable dimensions.
- .5 All incompatibilities between the specifications and drawings must be submitted in writing to the Engineer, so that he shall make and provide, also in writing, a final decision on them.
- .6 The specifications and drawings are complementary, so that what is required according to one is also required according to the other. The structure to be built, in accordance with the specifications and drawings, shall be a complete work in its essential parts, that is to say, it must include, in particular, all items normally resulting from the requirements of specifications and drawings, even if these items are not all specifically mentioned. The Contractor shall not profit, at the expense of Parks Canada, of any unintentional error, or omission that he may find. When the quality of work or materials is not precisely specified, the trades concerned must provide what there is of better quality.

- .7 The Engineer may, for clarification purposes only, provide the Contractor with additional drawings to ensure proper execution of the works. These drawings have the same meaning and the same scope as if they were included with the plans mentioned in the contract documents.

### **1.3 Description of the works**

- .1 The works covered by this contract primarily include, but not are not limited to:
1. The deck and approaches rehabilitation of the George-Étienne Cartier Pedestrian Bridge on the Lachine Canal.
  2. The construction of a pedestrian bridge at Lock No.4.
- .2 Specifically, the works include:
1. Maintenance of traffic, installation of a pedestrian bridge at the Lock No.4 and work signage.
  2. The complete demolition of the bridge deck, including its reconstruction.
  3. The painting of the various steel elements shown in the drawings, including the surface preparation.
  4. abutment walls concrete repairs.
- .3 The work covered by this contract are described in section "01110 - Summary of the work".

### **1.4 Materials provided by the Engineer**

- .1 Contractor's responsibility
1. Sort, transport and unload materials on the premises approved by the Engineer and ensure proper handling.
  2. All materials must be removed from the site.
  3. The Contractor shall repair any damage to the road (concrete slab and bituminous coating surface treatment), to the land (tree, turf, pavers, railways, etc.) and any other access used for the transportation of such materials and equipment.

**1.5 Work schedule**

- .1 The tenderer to whom Parks Canada Agency proposes to award the contract shall, within a period considered reasonable by the Engineer, submit a schedule showing the various stages of work progress and the estimated completion date. The contract award notice is subject to the approval, by the Engineer, of the work schedule.
- .2 According to the work schedule and in a form acceptable by the Engineer, deliver within five (5) business days following the contract award, the submission dates of shop drawings, lists of materials and samples.
- .3 Revisions of the progress of the work, according to the implementation schedule submitted, will be held at the discretion of the Engineer. The calendar will be updated by the Contractor with the cooperation and approval of the Engineer.

**1.6 Site visit**

- .1 To get acquainted with the conditions of the project and to obtain all the information necessary for the proper performance of the contract, do a site inspection at the structure location. Ignorance of site conditions shall not constitute, in any case, a valid reason to claim a payment.
- .2 If a site inspection certificate is required by the Parks Canada Agency, the date and time of the visit will be announced in the tender documents.

**1.7 Method of payment**

- .1 The Contractor will be required to ventilate his proposal as directed by the Engineer.

**1.8 Definition of unit and global prices**

- .1 It follows that, for the same unit or total price, the Contractor provides the materials, labor, tools, equipment and accessories required to perform the work.
- .2 The unitary or overall price also includes transportation and implementation of materials, as well as all the overhead, administration, insurance, contributions, interest, rent, taxes of the business and other incidental expenses.
- .3 It must cover the losses and damages resulting from the nature of the works, the fluctuation of prices and wages, business risks, strikes, delays not attributable to the Parks Canada Agency, accidents, action elements of nature and any other fortuitous event.

1. All costs incurred in relation with the requirements of Division 1 of the specifications will be paid according to article "Mobilization/Demobilization" of the bid form.

**1.9 Site benchmarking**

- .1 From the control lines and levels indicated on the plans, establish key benchmarks necessary for the execution of the work and provide all required materials.
- .2 Take the necessary measures to prevent the markers from being moved during the work.
- .3 Provide all the necessary equipment to allow the Engineer to the verifications considered necessary.
- .4 The canal water is usually at the approximate level indicated on the plans throughout the year. However, it is possible that the canal is emptied occasionally for maintenance purposes.
- .5 The Contractor may contact Parks Canada Representative to find out the periods when the canal is emptied.

**1.10 Permits, prescriptions and regulations**

- .1 The Contractor will be required to obtain the permits necessary for the execution of the works. He shall comply with all provincial, municipal or federal regulations and any other law or rules relating to these works. He will be required to assume responsibility for any violation of the relevant laws and regulations.
- .2 The Contractor shall assume (at its own cost) all obligations concerning security measures required by law on Health and Safety at work in Quebec and all obligations relating to mitigation measures described in the environmental evaluation report.

**1.11 Codes et standards**

- .1 Unless otherwise specified, perform the work in accordance with the Cahier des charges et devis généraux du MTQ (CCDG), the Canadian **Highway Bridge** Design Code (CAN / CSA-S6.00), the National Building Code of Canada (NBCC) and any other provincial or local codes. In cases of omission or contradiction between these standards, the most stringent requirements will apply.
- .2 The work must meet the requirements of standards, codes and other documents referenced or exceed them.



**1.12 Archeology****.1 Special Conditions**

- .1 National Historic Site of Canada has been recognized by the Canadian government as one of the sites with the highest heritage value. So on this site, all excavation of soil with possibility of containing archaeological remains must be monitored by an archaeologist appointed by the federal government.
- .2 Because of the potential to find archaeological remains during the excavation, these works are the subject of this section.

**.2 Access and collaboration**

- .1 The Contractor will cooperate and comply with guidelines of the project engineer during excavation, to avoid any loss of archaeological information on the site, if any.
- .2 The Contractor will facilitate access to work and collaborate with the archaeologist. The archaeologist or his representative will be based on site as required related to the protection and registration of the remains. Their role will be to guide the contractor to avoid any loss of archaeological information and gather information on the remains.
- .3 If necessary, the Contractor will allow the archaeological team to conduct examinations and archaeological surveys.

**.3 Archaeological Discoveries**

- .1 The Contractor shall notify the Parks Canada representative or, in his absence, the archaeologist or representative of any archaeological discoveries (remains of buildings or installations, objects and object parts) performed at the scene and wait its guidelines before continuing the work on site.
- .2 The remains, antiques and other items with some historical interest, archaeological or scientific (remains, object or object fragment) found on site or in areas to excavate or demolish are the property of the Crown. The Contractor shall protect and secure project manager's directives in this regard.

**.4 Works Suspension**

- .1 The Contractor shall provide in its contract, at its cost, stops of thirty (30) minutes per half-day excavation in the sectors requiring the presence of an archaeologist (as described in section 4.1 of this section). These stops, if not used, will be accumulated and can be reused as required subsequently. A statement of the unused time will be required by the Parks Canada representative in agreement with the contractor and the archaeologist.
- .2 If stops of more than 30 minutes are required, the representative of Parks Canada will assess the implications of this stops and advise the contractor for this purpose. The latter may be required to affect the machinery to another area to allow the continuation of work of archaeologists. If reassignment is not possible, the contractor will be compensated from the bank of hours or, if it is exhausted, according to the agreements provided during the kick-off meeting.
- .3 In case of accidental discoveries of cultural resources carried out in the absence of an archaeologist, the project manager and / or the prime contractor for the project must imperatively stop work in the immediate area of the discovery and notify project manager of the Parks Canada Agency.

**.5 Manual Excavations for Archaeological Purposes**

- .1 Given the possibility of archaeological discoveries, the contractor is notified that during work, the manual excavation may be required and all works necessary to ensure the protection of discoveries. The contractor will be compensated according to planned arrangements.

**.6 Protection of Remnants**

- .1 The Contractor shall take all reasonable precautions during excavations and works to protect the discovered remnants and allow examination by archaeologists. Parks Canada will not tolerate any derogation in this regard. If the contractor deteriorate by negligence some vestige whatsoever, he will be held responsible and the Ministry will consider the implications.
- .2 In the unlikely event where the Parks Canada representative authorizes the demolition of archaeological features on the site, the contractor will take the necessary precautions to protect the adjacent archaeological works that will not be demolished. The demolition of the elements must be carried out gradually and in a controlled manner after the archaeological surveys have been completed. If books are damaged during construction, notify the Parks Canada representative immediately.

**1.13 National Parks Act**

- .1 Proceed with all work to be performed within the limits of national historic sites, national historic parks, national parks and historic canals, in accordance with the National Parks Act.

**1.14 Use of the premises by the Contractor**

- .1 Restrict the use of the premises, to areas determined by the Engineer, for the execution of the work and storage.
- .2 Do not unduly accumulate materials or equipment to clutter the premises.
- .3 Move stored materials or equipment that hinders the work of the Engineer or another Contractor or Parks Canada operations.
- .4 For the duration of the work, do not use the site for shelter or temporary residence to the Contractor's employees.
- .5 After obtaining the required authorizations, assume the costs for the use of additional storage or work areas required for the execution of the work.

**1.15 Use of the premises by Parks Canada Agency**

- .1 The Contractor shall ensure access to the site to the authorized Agency personnel for, among other things, the verification of the behavior of the structures, the operation and maintenance of mechanical and electrical installations and other special elements.

**1.16 Existing networks**

- .1 When it comes to performing connection works to existing networks, proceed at the hours specified by the responsible authorities in order to create as little hindrance as possible to pedestrians, cyclists and vehicles.
- .2 Before proceeding with the work, determine the location and extent of underground public utility networks and notify the Engineer of these findings.
- .3 Submit the construction schedule to the engineer and obtain his approval for the temporary interruptions of existing networks or services. Proceed with the interruptions according to the approved schedule and notify in advance those affected.
- .4 In the event that non-identified installations are discovered during construction, immediately advise the Engineer and send a written report on the findings.
- .5 Remove all public utility networks abandoned within 2 m of the structures. Seal by means of a cap or other seal device, the pipes at the sections where they were cut and as directed by the Engineer.

- .6 Keep a record of the location of underground public utility networks that are either in service, diverted, or abandoned.
- .7 Repair any network failure caused by the works.

**1.17 Connection, ajustement and drilling**

- .1 Perform demolition and concrete work necessary with precision so that the structures which are to be connected or linked to others are done so according to the dimensions shown in the plans.
- .2 When the new structure element is connected to one already in place and that it is modified, perform the remediation work required to adapt the element already in place.
- .3 It is strictly forbidden to drill a supporting element.

**1.18 Site meetings**

- .1 The Contractor is required to attend site meetings.
- .2 The Engineer will organize the meetings and will be responsible for determining the hours and to prepare and distribute the minutes.

**1.19 Documents required on site**

- .1 Keep, on the site, a copy of each of the following documents:
  - 1. Drawings, specifications and contractual addendum;
  - 2. Complementary notes and drawings;
  - 3. Approved shop drawings;
  - 4. Modification authorisations;
  - 5. Test reports performed on the structure and materials;
  - 6. Approved schedule for implementation of the work.
  - 7. Installation, implantation and operational instructions provided by the manufacturer;
  - 8. Environmental Assessment Report (mitigation measures and negative residual impact evaluations).

**1.20 Restoration of site**

- .1 Restore all existing surfaces, peat, lots, landscaping, structures and services damaged during the construction works of this contract, in order to achieve equal or superior site conditions as opposed to the original ones.

**1.21 Snow removal**

- .1 The Contractor will be responsible to perform snow removal of the construction site and the site access during the entire construction period.
- .2 Snow removal is mandatory when the following conditions are met:
  1. Period of the day: 6:30 to 9:00 am or 15:30 to 18:00 pm
  2. Accumulation of 5 cm of snow
- .3 A maximum of four (4) hours shall be granted to the Contractor to clear snow from the areas mentioned.

**END OF SECTION**



**PART 1 - GENERAL**

**1.1 Section contents**

- .1 Works covered by the contract documents.
- .2 Type of Contract.
- .3 Work sequence.
- .4 Use of premises by the Contractor.

**1.2 Related sections**

- .1 Section « 01005 – General Instructions »
- .2 Tender Form

**1.3 Works covered by the contract documents**

- .1 Single contract: the work covered by this contract relate to the rehabilitation of the deck and the approaches of the George-Étienne Cartier Pedestrian Bridge, located on the Lachine Canal in Montreal include :
  - 1. Installation of a temporary confinement shelter;
  - 2. Construction of a pedestrian bridge at the Lock No.4 and the approaches.
  - 3. Demolition of the deck slab of the pedestrian bridge;
  - 4. Partial demolition of the existing structure (Backwall and approach spans);
  - 5. Cleaning and painting of the existing steel elements;
  - 6. Implementation of the new deck (metallic false decking, drains, concrete, reinforcement steel, trusses and angles with studs);
  - 7. Replacement of expansion joints at both approaches of the pedestrian bridge;
  - 8. Excavations and backfill at both approaches;
  - 9. Pavement rehabilitation at both approaches;
  - 10. Concrete reparation of abutment walls;

11. Signage and traffic management during construction;
  12. Bridge maintenance and snow removal at Lock No.4 during the duration of the work;
  13. All activities incidental to the work.
- .2 The works will generate the full closure of the pedestrian bridge throughout this period. A pedestrian bridge is to be constructed at Lock No.4.
- .3 The pedestrian bridge to be constructed shall respect all technical requirements described in the contract documents.

#### **1.4 Work Sequence**

- .1 Carry out the work in phases so as to maintain the structural integrity of the bridge deck and ensure the safety of the users.
- .2 Coordinate the work schedules with the site occupation by the Parks Canada Agency during construction.
- .3 Key steps to provide :
1. Construction of a pedestrian bridge at the Lock No.4;
  2. Maintenance of pedestrian and cycling traffic as well as the work zone signage;
  3. Excavation and contaminated soil management;
  4. Partial demolition of the deck slab and the backwalls;
  5. Production of expansion joints;
  6. Surface preparation and painting of steel elements;
  7. Installation of expansion joints;
  8. Concreting of new slab sections and new backwalls;
  9. Concrete reparation at approaches walls.
- .4 These steps are illustrative and the Contractor is responsible for identifying all the activities required to carry out the work and for developing its own sequence of work according to the contractual requirements.



**1.5 Use of the premises by the Contractor**

.1 The use of the premises by the Contractor is restricted to areas necessary for the execution of the work, the storage, and the access, to allow:

1. the site occupation by the Parks Canada Agency;
2. the execution of works by other contractors;
3. the use of the premises by the public;
4. the use of the Lachine Canal waterway.

**END OF SECTION**



**PART 1 - GENERAL****1.1 Measurement for payment**

- .1 The prices tendered for items in the Paid Items Table shall include labor, equipment and materials necessary to perform the work according to the plans and specifications and the instructions of the Engineer, including the following, but not be limited to:
  1. Coordination of the work, any necessary adjustments and corrections required on-site, the execution of the engineering and technical works required to ensure the execution of the works according to the rules of good practice and the requirements of the specifications;
  2. All traffic and signage control measures required near the Atwater pedestrian bridge to ensure the safe movement of the Contractor's equipment and the users of the nearby pedestrian and bicycle paths.
- .2 All the quantities leading to a payment are to be established, together with the Engineer, from measured readings. It is the Contractor's responsibility to proceed with these readings in good time and in a reasonable period. The amounts calculated for payment purposes shall be established in accordance with the nomenclature defined in this section.
- .3 Administrative expenses, profit as well as all the Contractor's direct and indirect costs related to the contract shall be included in the tendered prices for items in the quantity table. Costs incurred for the implementation of cold weather work shall be included in the payment item entitled « Working platform and shelter ».

**Items 1 – Site Organization****Item 1.1– Mobilization/Demobilization**

Mobilization and demobilization are payable on the basis of a lump sum.

The price tendered for this item shall include, but not be limited to:

- .1 The obtention of all permits and authorizations required along with the insurances and guarantees;
- .2 The provision of all contractual and professional documents required in the contract including, without limitation, the detailed schedule and the updates, the statutory declarations, the signed and sealed drawings, the different procedures, the conformity certificates and the attestations that are not specifically included in other pay items as well as manifests pertaining to the disposal of hazardous residual materials or special wastes;
- .3 The laboratories fees that the Contractor shall assume;
- .4 The services of a project manager and a superintendent;

- .5 The compliance to all safety measures;
- .6 The location and protection, if any required, of all utilities and other facilities, owned by Parks Canada or others, located in the work area;
- .7 All picket surveys, other than those specifically remunerated in the Paid Items Table, implementation site works required for completion of the work and the provision of the topographic surveys' electronic files for approval by the Engineer;
- .8 The provision of temporary works to enable the construction and the inspection of during construction works;
- .9 All components necessary for the execution of the work, according to specifications and drawings, whether these elements are or are not mentioned in the specifications and illustrated in the drawings;
- .10 The storage of machinery, equipment, materials, equipment, accessories and tools appropriate to the job site location;
- .11 The transport of materials at the site and from the site that is not specifically included in other payment items.
- .12 All temporary services and connections, such as water, electricity and sanitary facilities for the needs of the Contractor.
- .13 The provision of portable chemical toilets, including the handling and transport to the site and from the site and the maintenance required for the duration of their use;
- .14 The provision of all the guards, fences and other required safety measures for the protection of machinery, labor, materials, equipment, accessories, tools, walkways, platforms, scaffolds, enclosures, temporary supports, cofferdams, access devices and other floating or suspended installation;
- .15 The provision of all necessary fences to delineate the working and storage areas;
- .16 The maintenance, cleaning and restoration of the site and work areas;
- .17 The inspection of each work phase;
- .18 The removal and disposal, not specifically included in other payment items, of waste materials such as wastes, debris, pieces of demolished concrete, off-site and in a location provided for this purpose. and in accordance with specifications, for the duration of the contract at the end of the work;
- .19 The snow removal of work areas and designated zones by the contract.
- .20 The achievement of all the other work referred to herein and shown in the drawings, which are not included in the payment items 1.1 to 5.4 described therein;
- .21 The provision of all contractual documents required at the end of the contract including without limitation, the final statutory declarations, the « as built » drawings and any other documents required by Parks

Canada to complete the contract, not specifically included in the other payment items.

The lump sum for the work under this item is payable as follows:

- .1 An initial amount of 30% of the tendered amount for this item is payable when the general mobilization is completed;
- .2 A second amount equal to 50% of the tendered amount for this item is payable in proportion to the progress of the work of items 1.1 to 5.4 described therein;
- .3 The balance of the amount tendered for this item is payable when the general demobilization is fully completed.

If the Contractor does not present an implementation schedule of the work to the satisfaction of the Engineer as specified in the specifications, the Engineer will retain part or all of the payments for work already carried out, and that, until the schedule is submitted for examination to the Engineer and accepted by the latter.

### **Item 1.2 – Environmental protection**

Environmental protection is payable on the basis of a lump sum.

The price tendered for this item shall include, but not be limited to, all environmental protection measures and erosion control. The price also includes the supply of necessary materials, transportation, implementation, maintenance, and the dismantling of the measures.

The lump sum tendered for this item is payable in proportion to the progress of the present item.

### **Item 1.3– Working platform and shelter**

The working platform and shelter are payable by the meter of platform and shelter installed parallel to the pedestrian bridge.

The price tendered for this item shall include, but not be limited to, the design, procurement of design calculations and drawings by the Contractor signed and sealed by an engineer member of the Ordre des ingénieurs du Québec, the supply of materials and accessories, the necessary equipment, such as heaters, transportation, implementation, maintenance, inspections, condition monitoring reports and dismantling of temporary structures at the end of work.

The price tendered for this item is payable in proportion to the progress of construction and dismantling of temporary structures and according to the following limits:

- .1 A maximum of 60% of the amount tendered is paid once the construction of temporary structures is completed to the satisfaction of the Engineer;
- .2 The balance of the amount tendered is paid once the dismantling of temporary structures is completed to the satisfaction of the Engineer.

#### **Item 1.4– Maintenance of traffic and temporary signage**

The payment for the work included in the section « Maintenance of Traffic and Temporary Signage » of the maintenance of traffic document is based on a lump sum and includes, but is not limited to:

- .1 The maintenance of traffic and temporary signage;
- .2 The preparation of all signage plans;
- .3 The provision of all signaling personnel as well as the machinery and vehicles required for the temporary signage;
- .4 The mobilisation, maintenance and dismantling of accesses to the work;
- .5 The provision of flagmen, as required, for the access to the site;
- .6 The provision, mobilization, maintenance of traffic, maintenance, replacement in the event of breakage or vandalism, commissioning, displacement and demobilization of the temporary signage required to carry out the work on the entire site in accordance with the requirements of the present document;
- .7 The maintenance of signage including the inspections requested;
- .8 The survey of the existing vertical signage to be masked and its unmasking at the end of the work;
- .9 The temporary signage, equipment and manpower required for the completion of all work;
- .10 As well as other charges relating to the special maintenance of traffic requirements, as defined in sections 4.1 « Temporary Signage Plans » to 4.8 « Existing Signage » of the present document.
- .11 Special panels for signage. The price include the signed and sealed plans, the certificates, the installation of the panel including the equipment (trucks and nacelles), the poles, the bracing required, the hardware, the labor, the displacement as often as required, the maintenance or the replacement in the event of breakage or vandalism, the turning on and off as often as required, the demobilization at the end of the work and the temporary signage during such operations.

The payment starts at the beginning of the period and the maximum payable is the quantity provided for in the corresponding article.

**Items 2 – Temporary pedestrian bridge (Lock No.4)****Item 2.1 – Temporary pedestrian bridge – Furniture/Installation**

The provision and installation of the temporary bridge is payable on a lump sum basis.

The bid price for this position must include, but is not limited to, the provision of the Contractor's calculation notes and drawings signed and sealed from the temporary bridge by a member engineer from the Ordre des ingénieurs du Québec. The item also includes the provision of necessary materials, transportation, implementation, maintenance and disposal as well as any incidental expenses.

**Item 2.2 – Foundations**

The foundations of the temporary bridge are payable on a lump sum basis.

The bid price for this position must include, but is not necessarily limited to, the provision of materials, transportation, implementation and maintenance throughout the duration of the work as well as any incidental expenses.

**Item 2.3 – Ramps**

The foundations of the temporary bridge are payable on a lump sum basis.

The bid price for this position must include, but is not necessarily limited to, the provision of materials, transportation, implementation and maintenance throughout the duration of the work as well as any incidental expenses.

**Item 2.4 – Existing guardrail modifications**

The modification to the existing guardrails of the temporary bridge at the Lock No.4 are payable on a lump sum basis.

The bid price for this position must include, but is not necessarily limited to, the provision of materials, transportation, implementation and maintenance throughout the duration of the work as well as any incidental expenses.

**Item 2.5 – Approaches and path modifications**

The modifications to the existing approaches and path of the temporary bridge at the Lock No.4 are payable on a lump sum basis.

The bid price for this position must include, but is not necessarily limited to, the provision of bollard, materials, transportation, implementation and maintenance throughout the duration of the work as well as any incidental expenses.

**Items 3 – Deck rehabilitation****Item 3.1 – Concrete slab demolition**

Demolition of the concrete slab is measured for payment by square meter of slab demolished according to the drawings, the specifications and the instructions of the Engineer.

The price tendered for this item shall include, but not be limited to, the saw cut, the demolition of the expanded metal and reinforcing steel, the demolition of the existing steel decking under the concrete slab and the studs. The price also includes the supply of materials, equipment, implementation and disposal of demolition materials.

**Item 3.2 – Steel surface cleaning and painting**

Cleaning and painting of steel surfaces is payable on the basis of a lump sum.

The price tendered for this item shall include, but not be limited to, cleaning of the surfaces, the equipment, the supply of materials necessary for the implementation and painting of surfaces. All costs incurred for additional painting of surfaces due to the form of rivets, bolts, washers and nuts are included in the fixed price of the painting as well as any incidental expenses.

**Item 3.3 – Steel angles**

The 178 mm x 102 mm x 9.5 mm steel angle is measured for payment by the linear meter installed, according to the drawings, the specifications and the instructions of the Engineer.

The price tendered for this item shall include, but not be limited to, the equipment, the supply and installation of the angles including the welding done on-site and their control, the welding of studs on the angles and the implementation as well as any incidental expenses.

**Item 3.4 – Concrete slab (including steel deck)**

The slab concrete is measured for payment in cubic meter of concrete poured according to the drawings, the specifications and the instructions of the Engineer.

The price tendered for this position shall include, but not be limited to, the galvanized expanded metal and reinforcing steel, the steel deck, the equipment, the installation of temporary access structures, the manufacture and installation of formwork including all necessary accessories, adjustments to the forms, submittance of the concrete mixture formula, the supply, installation, finishing and curing of concrete according to the sequences shown in the drawings, the realization of construction joints, the formwork removal, the dismantling of all temporary access structures and the correction of surfaces. The costs related to this item must also include the provision of accessories, the equipment and the implementation as well as any incidental expenses.



**Item 3.5 – Drains**

The drains are measured for payment by the drain unit in place, according to the drawings, the specifications and the instructions of the Engineer.

The price tendered for this item should include, but not be limited to, the supply and installation of the drains, the equipment, and the necessary implementation as well as any incidental expenses.

**Items 4 – Expansion joints replacement****Item 4.1 – Excavation and backfill**

The excavation and backfilling work are payable on the basis of a lump sum.

Payment for this position will be made in proportion to the progress of the work.

The Contractor shall provide for the separation of dry materials in the soil before the disposal of contaminated soil. These materials must be disposed of in a site approved by Departmental Representative. To do so, the Contractor must provide a letter of agreement signed jointly by him and the site owner confirming its authorization to receive soil from this project. In order to be paid for the transport and disposal of these materials, these must be weighed with the help of a device, certified within one (1) year by an organization accredited by « Weights and Measures Canada ». The weighing coupons must be in numerical following order and provide the necessary space to write down the following information:

- .1 The name of the Contractor;
- .2 The date and time of arrival;
- .3 The name of the owner of the truck;
- .4 The registration number;
- .5 The origin of the transported materials;
- .6 The identification of the material and its degree of contamination;
- .7 The origin of the material;
- .8 The gross mass;
- .9 The empty weight of the truck;
- .10 The net mass;
- .11 The signature of the weigher.

The original coupon must be submitted to the Departmental Representative. The coupons that have been manually changed of by any other means, will not be compiled. Thus, the materials associated with these coupons will be considered as therefore having been disposed of at the expense of the Contractor. The price tendered for this item must include, without limitation, the provision of the letter of agreement for the chosen disposal site, the mechanical sorting (if required), the transportation of materials, the labor, the necessary equipment, and any incidental expenses.

The payment of this item will be made in proportion to the progress of the work.

**Item 4.2 – Demolition - backwall**

The demolition of the concrete is measured for payment on a lump sum basis.

The price tendered for this item shall include, but not be limited to, the saw cuts, the supply of materials, the equipment, the implementation and the disposal of demolition materials.

**Item 4.3 – Galvanized reinforcement**

The galvanized reinforcement steel is measured for payment by the kilogram of reinforcement installed, according to the drawings, the specifications and the instructions of the Engineer.

The price tendered for this item shall include, but not be limited to, the preparation and submittance of material lists (bar lists specifying the total mass of the lot (kg)), the supply of materials (including the galvanized steel bars, the metal rods for anchoring, the tie wire, the shims and the support bars), the equipment, the implementation and securing of the reinforcing steel.

**Item 4.4 – Concrete – backwalls**

The concrete for backwalls is measured for payment in cubic meter (m<sup>3</sup>) of concrete poured, according to the drawings, the specifications and the instructions of the Engineer.

The price tendered for this item shall include, but not be limited to, the equipment, the establishment of temporary work access, the construction and installation of formwork including all required accessories, the adjustments to formwork, the submittance of the concrete mixture formula, the supply, installation, finishing and implementation of construction joints, the formwork removal, the dismantling of all temporary work access and the correction of the surfaces. The price for this item shall also include the necessary equipment as well as the implementation.

**Item 4.5 – Expansion joints**

The replacement of expansion joints is paid by the meter, according to the drawings and the specifications and the instructions of the Engineer.

The price tendered for this item shall include, but not be limited to, the saw cuts, the removal of existing expansion joints, the stripping of work surfaces adjacent to the joints, the provision of reinforcement as well as their implementation, the provision and the implementation of new expansion joints, including on-site welding and the related controls, the shop drawings and includes any incidental expense.

**Item 4.6 – Asphalt– Approach spans**

The asphalt for the approach slabs is measured for payment in square meter (m<sup>2</sup>) of concrete poured, according to the drawings, the specifications and the instructions of the Engineer.

The price tendered for this item shall include, but not be limited to, the equipment, the installation of anchors and expanded metal as specified in the plans, the submittance of the asphalt mixture formula, the supply, installation, finishing and implementation of construction joints. The price for this item shall also include the necessary equipment and the implementation.

**Items 5 – Abutment walls repair works****Item 5.1 – Concrete demolition**

Demolition of the concrete is measured for payment by square meter of wall demolished according to the drawings, the specifications and the instructions of the Engineer.

The price tendered for this item shall include, but not be limited to, the saw cut and the demolition of the concrete. The price also includes the supply of materials, equipment, implementation and disposal of demolition materials.

**Item 5.2 – Dowels**

The dowels are measured for payment by unit of dowels installed, according to the drawings, the specifications and the instructions of the Engineer.

The price tendered for this item shall include, but not be limited to, the supply of the dowels and the chemical anchor product, the equipment, the drilling of holes and the implementation.

**Item 5.3 – Galvanized reinforcement**

The galvanized reinforcement steel is measured for payment by the kilogram of reinforcement installed, according to the drawings, the specifications and the instructions of the Engineer.

The price tendered for this item shall include, but not be limited to, the preparation and submittance of material lists (bar lists specifying the total mass of the lot (kg)), the supply of materials (including the galvanized steel bars, the tie wire, the shims and the support bars), the equipment, the implementation and securing of the reinforcing steel.

**Item 5.4 – Concrete**

The concrete is measured for payment in cubic meter (m<sup>3</sup>) of concrete poured, according to the drawings, the specifications and the instructions of the Engineer.

The price tendered for this item shall include, but not be limited to, the equipment, the establishment of temporary work access, the construction and installation of formwork including all required accessories, the adjustments to formwork, the submittance of the concrete mixture formula, the supply, installation, finishing and implementation of construction joints, the formwork removal, the dismantling of all temporary work access and the correction of the surfaces. The price for this item shall also include the necessary equipment as well as the implementation.

**END OF SECTION**

## PART 1 - GENERAL

### 1.1 General Requirements

- .1 The present section specifies the general requirements and procedures for the submission of shop drawings, product descriptions and samples by the Contractor to the Engineer for the purposes of their verification. (The other additional specific requirements are found in the appropriate sections).
- .2 Do not begin work before the documents or samples submitted have been verified by the Engineer.
- .3 Present shop drawings, product data, samples and mock-ups in SI Metric units.
- .4 Where items or information is (are) not produced in SI Metric units, converted values are acceptable.
- .5 The Contractor's responsibility of liability for errors and omissions in the documents submitted is not relieved by Parks Canada Representative's review.
- .6 At the time of submission of documents or samples, notify the Engineer, in writing, of any exemptions from the requirements of the contract documents, stating the reasons for these derogations.
- .7 The Contractor shall be held liable in respect of exceptions to contractual requirements, even if the Engineer checked the documents or samples submitted, except in the case where the latter agrees in writing to a given exemption.
- .8 Make all the changes the Engineer deems appropriate with regard to contractual documents and resubmit documents or samples as directed by the Engineer.
- .9 When resubmitting documents or samples, notify Parks Canada Representative in writing of revisions other than those requested.

### 1.2 Requirements related to the submittal of documents or samples

- .1 Coordinate the submission of documents or samples required with project requirements and contract documents. Documents or samples submitted individually will not be checked until all related information is available.
- .2 Allow five (5) days to the Engineer to verify the documents or samples submitted.

- .3 The cover letter provided in two (2) copies must contain the following information :
1. The date;
  2. The designation and the project number;
  3. The name and address of the Contractor;
  4. The name and the number of shop drawings, product descriptions and samples submitted;
  5. Any other relevant information.
- .4 The documents or samples submitted shall also bear the following information :
1. The preparation and revision dates;
  2. The designation and project number;
  3. The name and address of :
    - .1 The sub-contractor;
    - .2 The supplier;
    - .3 The manufacturer.
  4. The seal of the contractor accompanied by the signature of its authorized representative attesting that the documents or samples submitted have been approved, that the actions were verified on the spot and that everything is in compliance with the contract documents;
  5. The signature and stamp by a professional engineer registered or licensed in the Province of Quebec, Canada;
  6. Details of the appropriate parts of the works, as required:
    - .1 Fabrication details.
    - .2 Layout details showing dimensions, including identified field dimensions, and clearances.
    - .3 Setting or erection details.
    - .4 Capacities of the elements or of the entire structure.
    - .5 Characteristics relating to performance or efficiency ;
    - .6 Applicable standards ;

- .7 Design weight ;
- .8 Wiring diagrams (if required) ;
- .9 Relationship to adjacent work.

- .5 Once the engineer has checked the documents submitted, distribute copies.

**1.3 Shop drawings**

- .1 Shop drawings : original drawings or modified standardized drawings provided by the Contractor and illustrating the parts of the structure that applies to the current works.
- .2 Maximum dimensions of drawings 750 x 1000 mm.
- .3 Submit shop drawings as follow :
  - 1. One (1) electronic copy (PDF format) and four (4) printed copies.
- .4 Make necessary references to appropriate parts of the contract documents.

**1.4 Product description**

- .1 Product description : manufacturer's catalog pages, performance or return graphs and diagrams to illustrate standard manufactured products.
- .2 Submit four (4) copies of the product's description.
- .3 Datasheet dimensions: 215 x 280 mm, maximum of three (3) modules.
- .4 Delete any information that does not apply to the present works.
- .5 Add to the standard information any additionnal information relevant to the present works.
- .6 Make the necessary references to appropriate parts of the contract documents.

**1.5 Product samples**

- .1 Samples : material samples, equipment, quality, finish or execution mode.
- .2 If the color, pattern or texture are to be used as selection criteria, submit the full range of product samples.

- .3 Once checked and approved, the product samples will serve as quality standard for the purposes of the present works.

**1.6 Work samples**

- .1 Samples : works carried out on site using the materials and the prescribed execution mode.
- .2 Realize the work samples in places deemed acceptable by the Engineer.
- .3 Once checked and approved, the work samples will serve as quality standard for the purposes of the present works.

**1.7 Shop drawing review**

- .1 The review of the shop drawings by Parks Canada or its representatives has the sole purpose of ensuring compliance with the general concept. This review does not mean that Parks Canada or its representatives approve the detailed design shop drawings attached, which remains the responsibility of the Contractor who submits them, and such a review does not relieve the Contractor from its responsibility to all errors or omissions on the shop drawings or to observe the construction requirements and contract documents. Without limiting the foregoing general considerations, the Contractor is responsible on the site, for the manufacturing or construction techniques and installation and also for the coordination of the work of all subcontractors.

**1.8 Temporary works plans**

- .1 The expression « temporary works plans » means the plans of shoring, scaffolding, enclosures, walkways and other access devices, plans of environmental protection measures, lane closures plans, transportation plans of material and equipment, traffic signage plans, lifting plans, methods of work and calculation notes, drawings or other documents necessary for the performance of the work, based on specifications, drawings and the site conditions.
- .2 The plans for the temporary works and attached documents must bear the signature and stamp of a professional engineer registered or licensed in the Province of Quebec, Canada.
- .3 Following their installation, an inspection and a certificate of conformity signed and sealed by the same engineer who signed the plans must be submitted.

**END OF SECTION**



**PART 1 - GENERAL**

**1.1 Requirements**

- .1 The specific requirements for the inspection and testing to be carried out by the laboratory appointed by the Engineer are specified in various sections.

**1.2 Appointment and payment (PC)**

- .1 The Engineer shall designate the laboratories that will conduct the testing and bear the costs of their services, except in the following cases:
1. Essais spécifiés comme devant être effectués par l'Entrepreneur sous la supervision de l'Ingénieur;
  2. Inspection and testing required by the laws, ordinances, rules, regulations or public policy guidelines;
  3. Inspection and testing performed solely for the convenience of the Contractor;
  4. Testing related to the adjustment and balancing of the handling systems, networks and mechanical and electrical equipment;
  5. Factory testing and compliance certificates;
  6. Testing specified as to be performed by the Contractor under the supervision of the Engineer.
- .2 When testing or inspections results, from testing laboratories, reveal a non-compliance of the works in regards with the contract requirements, the Contractor shall bear the cost of additional tests that the Engineer may require to verify the acceptability of corrections.

**1.3 Contractor's responsibility**

- .1 Provide labor and facilities for :
1. Provide access to structures to be inspected and tested;
  2. Facilitate inspections and tests;
  3. Rehabilitate works disturbed during inspections and testing.

- .2 Notify the Engineer sufficiently in advance of the site operations to enable him (her) to make an appointment with the laboratory personnel and establish the testing schedule.
- .3 When materials must be tested, ship to the test laboratory the requested representative sample quantities.
- .4 Cover the costs for work performed to expose and restore the structures that were covered before the inspection or required tests have been completed and approved by the Engineer.

**END OF SECTION**

**PART 1 - GENERAL****1.1 Sanitary facilities**

- .1 Provide workers with sanitary facilities that comply with the regulations and ordinances in effect.
- .2 Post notices and take the required precautions by local public health authorities. Ensure sanitary conditions of premises and facilities at all time.

**1.2 Parking**

- .1 The Contractor is responsible for obtaining the necessary authorizations from the authorities concerned to set up parking areas outside the site. Maintain and administer the parking areas according to the instructions from the authority having issued the authorizations and the Engineer.

**1.3 Electric power**

- .1 Provide temporary electricity supply and to meet the cost and maintenance according to regulations and ordinances.

**1.4 Water supply**

- .1 Ensure temporary drinking water supply, to meet the cost and maintenance according to regulations and ordinances. In no way the contractor is allowed to use the canal water.

**1.5 Heating and ventilation**

- .1 Pay for temporary heating and ventilation systems used during construction, including installation costs, fuel, operation, maintenance and removal of equipment. He will be allowed to use direct fired heaters that spread fumes in work areas if the Engineer has previously authorized. Supply and install temporary heating equipment and ventilation required on site to:
  1. Facilitate the execution of works.
  2. Protect the books and materials against moisture and cold.
  3. Prevent moisture condensation on surfaces.

**1.6 Construction site enclosure**

- .1 Erected around the sites, a temporary fence. Provide a lockable door for trucks. Keep the fence in good condition.

- .2 Fences should be constructed to facilitate the installation of materials and labor within the site. Fences demarcating the construction areas must be permanently closed.
- .3 Fences should be designed to resist wind.
- .4 During periods of activity, temporary fences must be positioned to completely block access to the bridge users. The Contractor shall ensure that they have fences around the perimeter of the gateway at a reasonable distance from the latter, so as to ensure the safety of users and workers, and that, according to the engineer's requirements.
- .5 Note that the bridge must remain open to users outside of working hours. The Contractor is responsible therefore to have fences, during periods of inactivity, so that users of the gateway to travel safely there.

**1.7 Removal of temporary facilities**

- .1 .Remove all temporary installations from the site where the Engineer deems it appropriate.
- .2 When work is interrupted at the end of the construction season, assume the service of the facilities until the Engineer authorizes the interruption.

**1.8 Access platform**

- .1 Design and construct scaffolds in accordance with CSA Standard S269.1-1975 and the requirements of Section 01545 - Safety Measure.
- .2 Where necessary, scaffolds shall be attached near the nodes of the structure and shall be removed promptly when no longer required. A workshop plan showing the details of the platforms must be submitted to the Engineer for approval.
- .3 All costs related to the construction of work platforms shall be included in item 1.3 "Work Platform and Shelter" as described in Section 01290 - Measurement for Payment.

**END OF SECTION**

## **PART 1 - GENERAL**

### **1.1 Scope of temporary signage work**

- .1 The work includes, but is not limited to, providing and installing temporary signage required for the maintenance of traffic and protect workers during the installation and dismantling of a temporary pedestrian bridge at lock no. 4 (Côte-St-Paul Lock) as well as during the rehabilitation of the deck and bearings of the Sir George-Étienne Cartier Pedestrian Bridge, overlooking the Lachine Canal in the southwestern borough of the city of Montreal, as well as all related work specified in all contract documents.
- .2 The work covered by the present document includes, but is not limited to:
  - .1 the preparation of all temporary signage plans;
  - .2 the mobilization, the maintenance of traffic, the upkeep, the relocation, the replacement, the turning on or off, the demobilization of the temporary signage panels, all in accordance with the requirements of the present document;
  - .3 the upkeep of the signage;
  - .4 the manufacture, the installation, the maintenance of traffic, the upkeep, the relocation, the replacement, the turning on or off, the demobilization of the special signage panels;
  - .5 the provision of flagmen if required;
  - .6 the temporary signage, the equipment and manpower required for the completion of all the work mentioned above;
  - .7 and all other work required for the complete execution of the project in a safe environment for road users, pedestrians, workers and shoreline residents, as well as the related work required to complete the work described in the present document.

### **1.2 Location**

- .1 The temporary signage work is located near the Lachine Canal in Montreal. For the temporary signage work, the limits of the work site are defined as :

Northern limit:	St-Ambroise Street
Eastern limit:	Atwater Pedestrian Bridge
Western limit:	Côte-St-Paul Road
Southern limit:	St-Patrick Street

- .2 However, the Contractor may be required to operate in a wider area when installing peripheral indication signs or any other work described in the tender documents.

### **1.3 References**

- .1 The work signage must comply with the requirements included in the last editions of the following reference documents, unless otherwise indicated in the present document:
  - .1 Code de la sécurité routière du Québec;
  - .2 Code de sécurité pour les travaux de construction, chapitre S-2.1, r. 4
  - .3 Cahier des charges et devis généraux, infrastructures routières, construction et réparations, Transports Québec – CCDG, latest edition;
  - .4 Tome III – Ouvrages d’art de la collection Normes – Ouvrages routiers du ministère des Transports – Tome III, latest edition;
  - .5 Tome V – Signalisation routière, volumes 1, 2 et 3 de la collection Normes – Ouvrages routiers du ministère des Transports – Tome V, latest edition;
  - .6 Tome VII – Matériaux de la collection Normes – Ouvrages routiers du ministère des Transports – Tome VII, latest edition.
- .2 The Contractor must take note that the schedule for the upgrading of signage devices in Tome V is not valid for this contract. The contractor must therefore comply with the signage standards in force on the date of the opening of tenders.

## **2.0 SEQUENCE OF REALIZATION OF THE WORK**

### **2.1 Description**

- .1 The maintenance of traffic for the rehabilitation work of the bridge deck and bearing devices of the Sir-George-Étienne Cartier Bridge is subdivided into three (3) phases: Preparatory phase, Phase 1 and Phase 2.

#### **.1 Preparatory phase**

- .1 The preparatory phase includes, but is not limited to:
  - .1 The installation of a temporary pedestrian bridge at Lock No. 4.
  - .2 To carry out the work of this phase, the Contractor is authorized to completely close the doors on the downstream side of Lock no. 4.

- .3 It is the responsibility of the Contractor to set up the detour route set out in Appendix 1 of the present document, in accordance with the current standards.
- .4 The Contractor must limit himself to the use of the work area shown in Appendix 1 for the execution of his work.

**.2 Phase 1**

- .1 The main work in phase 1 comprises, but is not limited to:
  - .1 Partial demolition of the existing structure (backwall, approach slab);
  - .2 Demolition of the slab of the pedestrian bridge deck;
  - .3 Installation of the new deck (metal false-decking, drains, concrete, reinforcing steel, lattices and angles with dowels);
  - .4 Without finishing oversize concrete repair of the approach wall;
  - .5 Cleaning and painting of existing steel elements;
  - .6 Replacement of expansion joints at both approaches to the pedestrian bridge;
  - .7 All other incidental activities.
- .2 In order to carry out the work of this phase, the Contractor is authorized to completely close the Sir-George-Étienne-Cartier pedestrian bridge. It is the responsibility of the Contractor to set up the detour route shown in Appendix 2 of the present document, in accordance with the current standards.
- .3 The Contractor must also maintain in a close position the downstream doors of Lock no. 4. To do this, the Contractor must provide for the use of a self-supporting fence with a width of 1.8 m and a height of 2.4 m and which he must fix firmly.
- .4 The contractor must limit himself to the use of the work area illustrated in Appendix 2 for carrying out this work.
- .5 Work on the preparatory phase must be completed before the beginning of Phase 1 work.

**.3 Phase 2**

- .1 The main work in phase 2 comprises, but is not limited to:
  - .1 Partial demolition of the abutment walls;
  - .2 Oversize concrete repair of the abutment walls;
- .2 While carrying out the work of this phase, no partial or complete obstruction of the Sir-George-Étienne-Cartier pedestrian bridge is authorized. The Contractor must limit himself to the use of the work area illustrated in Appendix 3 for the execution of this work.

**2.1 Restrictions regarding the realization of work**

- .1 The Contractor must manage the pedestrian and cycling traffic so that there are no users moving on the downstream side of Lock no.4 during the execution of the works as well as on the Sir- George-Étienne-Cartier during the completion of Phase 1 work.
- .2 For the year 2017, the Contractor must take into consideration the navigation schedule in the Lachine Canal and ensure that it does not impede the passage of boats.

**2.3 Table 0-A Additional constraints**

PERIOD	DAYS	ADDITIONAL CONSTRAINTS
October 18 <sup>th</sup> 2017 to December 16 <sup>th</sup> 2017	Every day	Lowered water level



### **3.0 CLOSURE OF THE LOCK NO. 4 DOWNSTREAM DOORS AND OF THE SIR-GEORGE-ÉTIENNE-CARTIER PEDESTRIAN BRIDGE**

#### **3.1 Application for cycling path lane closures and delays**

- .1 In order to carry out the work requiring the closure of the Lock no. 4 downstream doors and the Sir-George-Étienne-Cartier pedestrian bridge, an application must be sent to the Departmental Representative at least three (3) working days before the schedule closure. The forms required to complete closure applications must be requested by the Contractor at the start-up meeting. The applications transmitted are analyzed and coordinated with other requests from other contracts before the closure is authorized. The Departmental Representative accepts unaltered, modified or rejected closure requests at least twenty-four (24) hours before the scheduled closure begins. Only cancellations are possible after 12:00 pm on the day of closure. No revision, addition or modification to the closure application will be accepted after this deadline.
- .2 Costs related to closure applications are considered as contract overhead fees and their payments are distributed throughout the various items in the maintenance of traffic document.

### **4.0 MAINTENANCE OF TRAFFIC AND TEMPORARY SIGNAGE**

- .1 The objectives of maintenance of traffic are to ensure, on the one hand, the safety of users and workers and, on the other, to maintain the fluidity of traffic.
- .2 The Contractor is responsible for ensuring the flow of traffic in accordance with the requirements of the present document for the duration of the work.
- .3 The Contractor may make its proposals, if necessary, in accordance with the CCDG's « Spirit of Contract » article by submitting a proposed amendment to the contract. In this case, the Contractor must clearly demonstrate the benefits of productivity and maintenance of traffic.

#### **4.1 Temporary signage plans**

- .1 Notwithstanding the format and timing of transmission, the Contractor shall provide temporary signage plans in accordance with Articles 6.6 « Plans de signalisation » (Plans Provided by the Contractor) and 6.6.4 « Plans de signalisation » (Signage Plans) of the MTQ's CCDG. The plans must include the maintenance of traffic plans that represent each phase of work. They must also include the detour plans, the design plans for the fabrication of detour and special signage panels, the plans required for the management of pedestrians and cyclists. The plans must be true to the actual terrain conditions (horizontal and

vertical curves) and indicate the location of the access to the site.

- .2 The temporary signage plans shall be produced in 279 mm x 432 mm (11"x 17") electronic PDF format and the transit time for the temporary signage plans shall be ten (10) days before the signage is installed.
- .3 The submittance of the plans to the Departmental Representative within the prescribed period is prior to the authorization to start the work.

#### **4.2 Access to work areas and protection**

- .1 Entry and exit operations must be safe and carried out in such a way as to ensure complete protection for workers, road users, cyclist and pedestrian.
- .2 Thus, the Contractor and its subcontractors must provide for the use of flagmen at all times to manage any vehicle entering or leaving a work area adjacent to the bicycle path or traffic lanes.
- .3 In addition, as a safety measure, the Contractor must provide for a flagman to escort, at all times, the vehicles or machinery that circulate on the bicycle path.
- .4 Procedures for access to work areas must be provided to the Departmental Representative prior to the commencement of work.
- .5 It is the Contractor's responsibility to obtain the permits from the various public owners to exploit the work areas shown in appendices 1, 2 and 3. Work areas must be kept closed with construction site fencing at any time during the use thereof.
- .6 All vehicles accessing the work area through access to the work site must be equipped with a rotating beacon.
- .7 All accesses must be kept closed with construction site fencing when not in use. During periods of work, the accesses may be kept open in order to facilitate the entry and exit of authorized vehicles. However, the Contractor must under no circumstances carry out work or store material or equipment near the accesses to the site.

#### **4.3 Storage of material and equipment**

- .1 At all times, even outside working hours (evenings, weekends and holidays), the Contractor must park the machinery and equipment and store the materials in a safe manner both for the road users and bicycle path users and on adjacent properties. The storage site is subject to approval by the owner.

#### **4.4 Specific requirements concerning the maintenance of traffic and temporary signage**

- .1 Where sign panels are no longer relevant, the Contractor shall pick them up or render them inoperative without delay, as follows:
  - .1 Work signage panels and special panels that are not in operation must be removed and picked up or hidden according to one of the options in Figure 4.44 1 « Masquage des panneaux » (Panel Masking) in Volume V. Only one option must be applied to the entire area and the Contractor must specify, at the beginning of the work, the option he has chosen.
  - .2 According to Option 3 in Figure 4.44 1 « Masquage des panneaux » (Panel Masking) in Volume V, the rigid cover shall be black and identified on the back with the name of the signage company (name and telephone number). The dimensions of the retro-reflective strip must however be 80 mm thick and cover the entire width of the panel to be masked. The only alternative to masking signs is to pick them all up, including weights.

#### **4.5 Signage material**

##### **4.5.1 Visual markers**

- .1 The accepted visual markers are the T-RV-2, T-RV-7, T-RV-8, T-RV-9 and T-RV-10.
- .2 Visual markers shall conform to the requirements of Volume V and those of Article 4.4 of the present document as to form and color and the reflectivity of the retroreflective sheeting shall be not less than 50%. The visual markers must be in good condition, well positioned (turned on or off), in sufficient quantity and clean.

##### **4.5.2 T-B-2 Barriers**

- .1 In addition to the requirements of Volume V and those of Article 4.4 of the present document, each end of the pedestrian bridge or lane closed to traffic shall have one or more T-B-2 barriers.
- .2 The T-B-2 Barriers shall comply with the requirements of Volume V and those of Article 4.4 of the present document and shall be in good condition, well positioned (turned on or off), in sufficient quantity and clean.

##### **4.5.3 Work signage panels**

- .1 The work signage panels are the ones specified in the standard drawings of Tome V, modified according to the conditions of work of the present contract and those included in Appendix B « Dispositifs de signalisation pour les travaux » (Signage devices for works) of Chapter 4 « Travaux » (Works) of Tome V.

- .2 The minimum dimension of the work area signs shall correspond to the speed displayed on the white background P 70 panel and the standards indicated in Volume V.
- .3 The work signs must be manufactured according to the MTMDET manufacturing specifications available on the Transport Québec site at [www.rsr.mtq.qc.ca](http://www.rsr.mtq.qc.ca).
- .4 In addition to the requirements of Volume V and Section 4.4 of the present document, all work signage, including special signage and detour signage, shall meet the following requirements:
  - .1 All panels mobilized for more than three (3) consecutive days must be installed permanently (planted in the ground or fixed on a rigid concrete barrier) and located at the outer limits of the shoulder;
  - .2 When the weighted panels are placed on the shoulder, they must be located as far as possible from the traffic lanes;
  - .3 When the signs are located near the sidewalks, they must completely clear the sidewalk and be installed at a height of 2.2 m from the ground.
- .5 In addition to the requirements of Volume III, all posts planted and whose lateral panel clearance (work signage or special panels) is lower than that indicated in the chart on page 3 of chapter 2 « Sécurisation des abords de route » (Securing the surroundings of Route) of Volume VIII must correspond to those included in the homologation list of program HOM 6310 101 for « Support cédant sous impact – Petite signalisation ». (Support breaking under impact - Small signage).
- .6 Prior to planting the posts, the Contractor must make all the necessary checks to ensure that no utility or buried structures are damaged.
- .7 The panels shall comply with the requirements of Volume V and with those of Article 4.4 of the present document as to their shape and color and the reflectivity of their retroreflective sheeting shall not be less than 50%. They must be in good condition, well positioned (turned on or off), in sufficient quantity and clean.

#### **4.6 Maintenance of signage devices**

- .1 When the signage devices are in place, either turned on or off, the Contractor must provide the labor, equipment and material necessary to perform regular cleaning of the devices (visual markers, T-B-2 barriers and work signage panels) in order for them to maintain their reflectivity.
- .2 In addition to a regular maintenance as defined above, a maintenance crew must also conduct a full inspection of the site each day for a minimum of four (4) hours and perform all the necessary corrective measures to the temporary signage. Before beginning each inspection, the maintenance crew must report their presence to the Departmental Representative. In addition, a daily report for each inspection must be provided to the Departmental Representative at the end of each visit. A copy of the inspection report to be completed by the inspection team

will be provided to the Contractor at the start-up meeting.

#### **4.7 Maintenance of traffic lanes**

- .1 The Contractor is responsible for the maintenance of the lanes used by the road users, including the bicycle lanes and footpaths, during the construction period, within the limits of the site. More explicitly, the contractor is responsible for:
  - .1 To clean the paved surfaces where traffic is maintained and to keep them free from debris, liquid or solid material whether the material (sand, earth, gravel, etc.) comes from the construction site, the roadway traffic or by inclement weather;
  - .2 To take all the necessary measures to prevent the deposit of these materials on the roadway and to intervene immediately to remove them, if necessary;
  - .3 Maintain the work area and roadways so that there is no dust emission;
  - .4 Ensure the proper drainage of roadways;
  - .5 Of any other work necessary for the proper maintenance of traffic.

#### **4.8 Existing Signage**

- .1 Prior to authorization of commencement of work and jointly with the Departmental Representative, the Contractor must make a site tour to identify the existing signage to be masked.
- .2 The Contractor must, in conjunction with the Departmental Representative, and before the beginning of the work, make a detailed survey of the signage to be masked.
- .3 For each of these panels, this survey must include at least one picture of the panel as well as a sketch of its location (position, clearance and height). A copy of this survey must be given to the Departmental Representative prior to authorization to commence work.

#### **4.9 Payment mode**

- .1 The payment for the work included in the section « Maintenance of Traffic and Temporary Signage » of the maintenance of traffic document is based on a lump sum and includes, but is not limited to:
  - .1 The maintenance of traffic and temporary signage;
  - .2 The preparation of all signage plans;
  - .3 The provision of all signaling personnel as well as the machinery and vehicles required for the temporary signage;

- .4 The mobilisation, maintenance and dismantling of accesses to the work;
  - .5 The provision of flagmen, as required, for the access to the site;
  - .6 The provision, mobilization, maintenance of traffic, maintenance, replacement in the event of breakage or vandalism, commissioning, displacement and demobilization of the temporary signage required to carry out the work on the entire site in accordance with the requirements of the present document;
  - .7 The maintenance of signage including the inspections requested;
  - .8 The survey of the existing vertical signage to be masked and its unmasking at the end of the work;
  - .9 The temporary signage, equipment and manpower required for the completion of all work;
  - .10 As well as other charges relating to the special maintenance of traffic requirements, as defined in sections 4.1 « Temporary Signage Plans » to 4.8 « Existing Signage » of the present document.
- 
- .2 The payment starts at the beginning of the period and the maximum payable is the quantity provided for in the corresponding article.

## **5.0 SPECIAL PANELS**

### **5.1 Description**

- .1 At the Departmental Representative's request, the Contractor manufactures and installs special panels. The special panels are manufactured on plywood sheets ( $\frac{3}{4}$ " ) or aluminum panels. Each panel must be made up as shown in the right-hand illustration of Figure 4.20 2 « Montage avec les panneaux « Détour » » (Mounting with the "Detour" panels) Volumes V or according to the specifications transmitted by the Departmental Representative. The panels of series T-90 will not be paid since they are part of Appendix B « Work Signage devices » of Chapter 4 « Travaux » (Works) of Volume V and shall be considered to be work signage panels. The special panels shall be covered with a retroreflective orange type IV film. The lettering shall be black in color and, where required, the numbering badge of the road concerned is made of a high-intensity type IV film.
- .2 At the request of the Departmental Representative, the sign panels may have to be manufactured on « coroplast » if they are intended to be installed on existing panels.
- .3 The special panels are panels complementary to the work signage panels and may also be signs of prescription or danger requested by the Departmental Representative. They must meet the Departmental Representative's requirements as well as the requirements specified in section 4.5.3 « Work Signage » in the present document.

- .4 The special signage panels may be installed on weighted or planted surfaces as required by section 4.5.3 or as specified by the Departmental Representative.
- .5 For each type of installation, the Contractor must provide a plan, signed and sealed by an engineer member of the OIQ, showing the details of the panel, the hardware required and the location of its installation.
- .6 The special signage panel remain the property of the Contractor.
- .7 All special panels must be available for the duration of the contract.

### **5.1.1 Warning Panels**

- .1 Prior to the commencement of the work, the Contractor shall install four warning signs for marine traffic, one upstream and one downstream of the bridge under construction and a warning sign at the temporary bridge, one on the upstream side and one on the downstream side.
- .2 The signs on the temporary pedestrian bridge at Lock no. 4 must conform to the D-190-1 « Height Limitation » sign and indicate a clearance of 2.5 m.



- .3 The panels must meet the following requirements for the Sir George-Étienne-Cartier Pedestrian Bridge:

### 5.1.2 Construction work signage location and specifications

1. **Installation and orientation:** The warning signs should be placed according to instructions and must be visible at a distance of 50 meters from the river.
2. **Dimensions (min.) of the panel:** 1200 mm x 1200 mm (4 'x 4').
3. **Dimensions (min.) Lettering:** Lettering for the title must be at least 1.5 times the height of the message. The lettering (message) must be at least 140 mm high.
4. **Color and contrast:** International Yellow (Pantone Matching System® - Yellow).
5. **Construction:** Wood/plastic/steel panels and reflective film (Diamond Grade (TM) 3M (TM) or equivalent), international yellow (Pantone Matching System® - Yellow).
6. **Maintenance:** Must be maintained throughout the construction period.





APPENDIX 1 - Detour routes – Preparatory Phase and temporary pedestrian Bridge dismantling

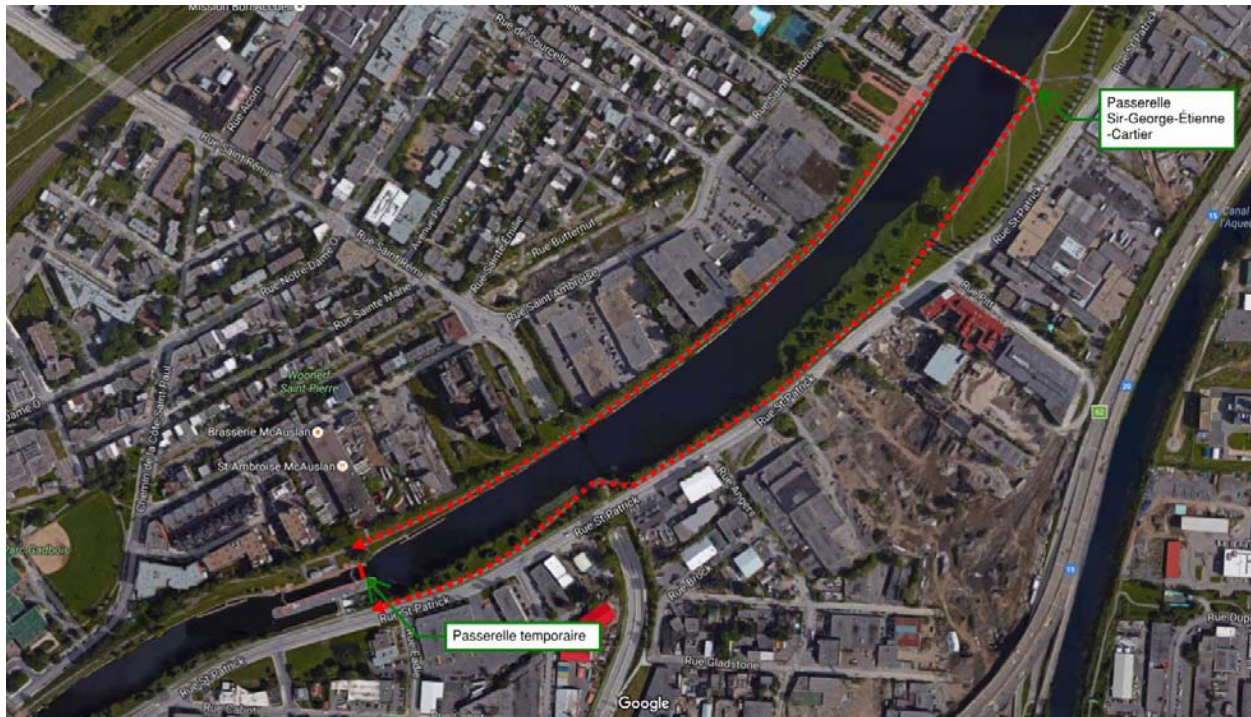

Figure 1- Cycling detour

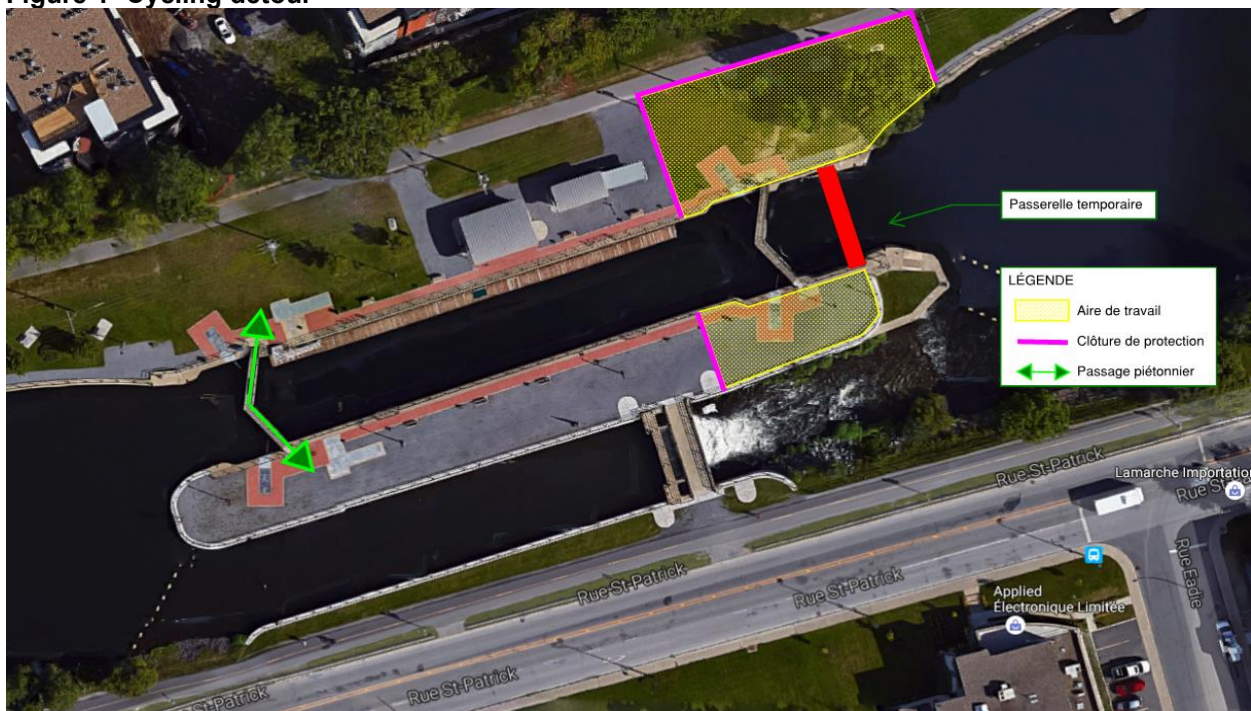

Figure 2 – Pedestrian detour and work area



APPENDIX 2 - Detour routes - Phase 1

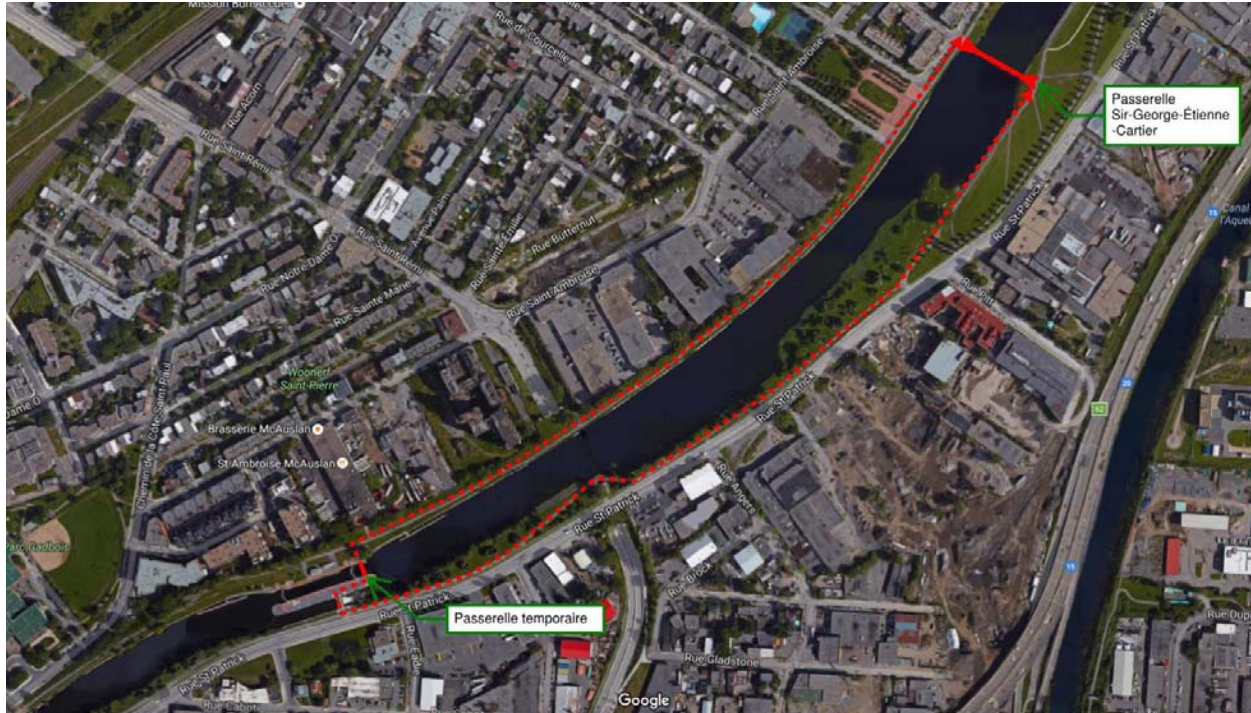

Figure 3 - Cycling detour

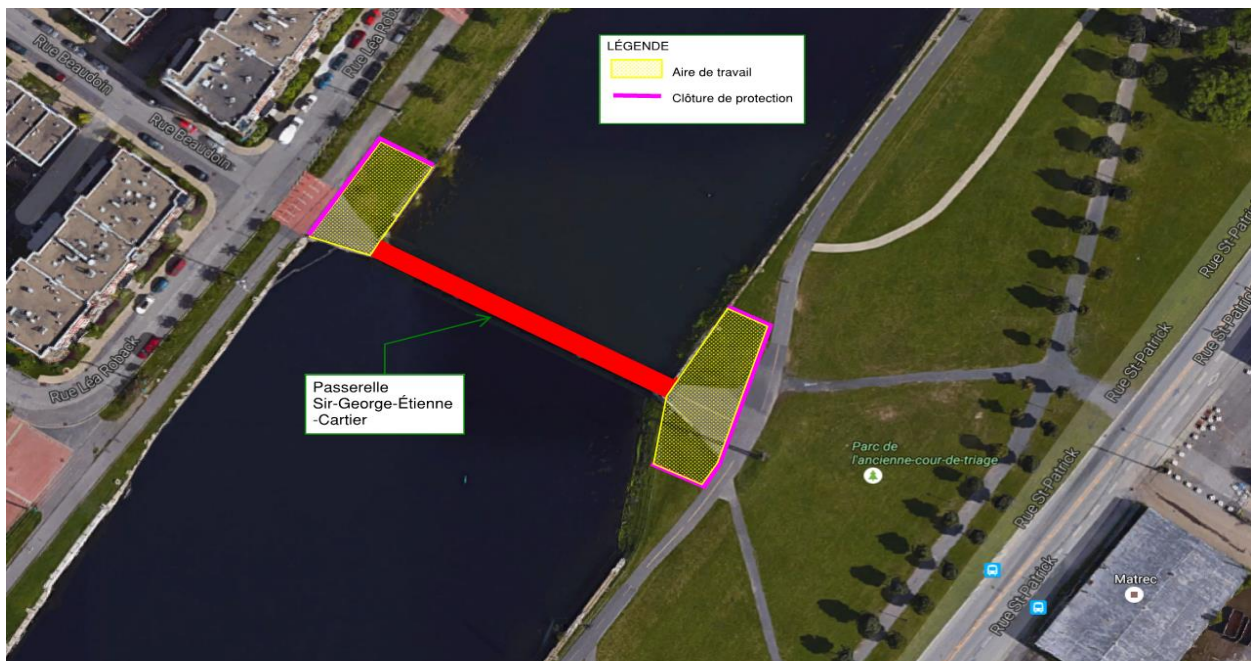

Figure 4 – Work area

APPENDIX 3 - Work areas - Phase 2

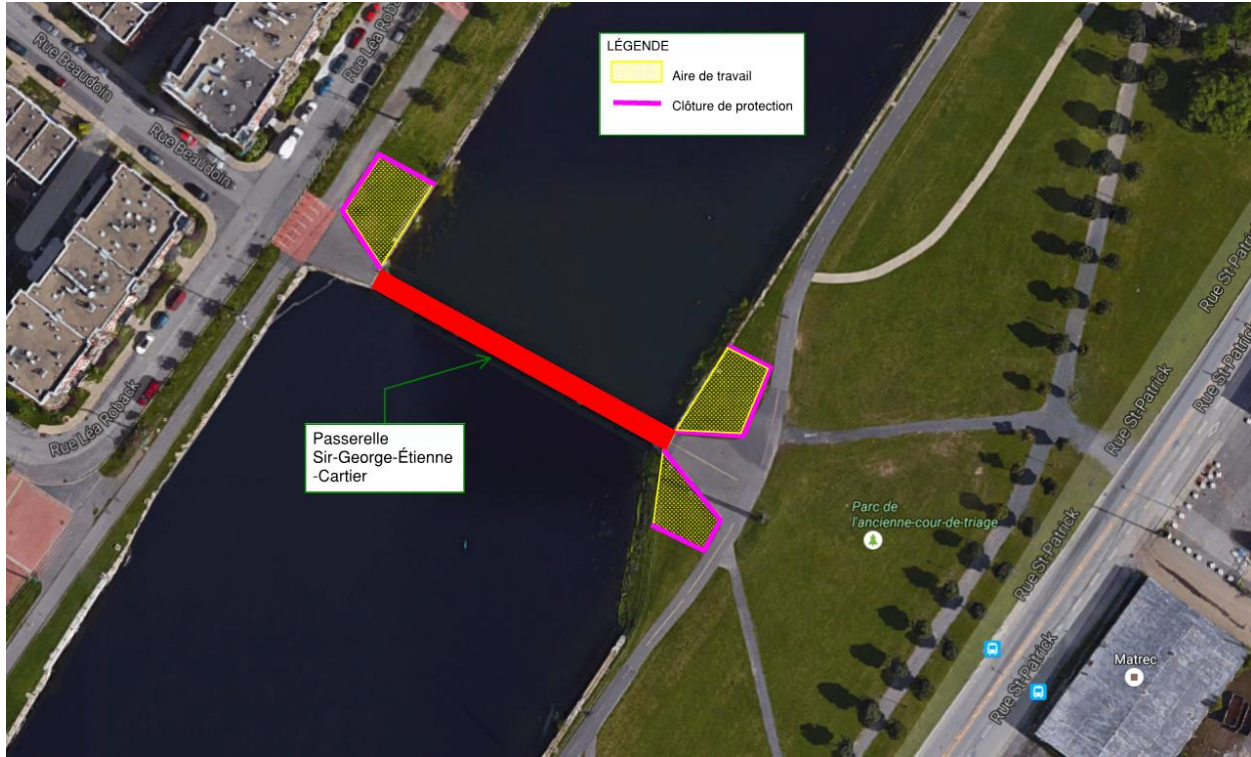

Figure 5 – Work areas

END OF SECTION



**PART 1 - GENERAL**

- .1 The Contractor shall manage its activities so that the health and safety of the public and the site personnel as well as the environmental protection always have precedence over issues related to cost and schedule.

**1.1 Legal and normative references***(Current editions)*

- .1 Canada Labour Code - Part II, Canadian Regulations on Safety and Health at Work.
- .2 Canadian Standards Association (CSA).
- .3 Health and Safety Act, RSQ Chapter S-2.
- .4 Safety Code for the construction work, 2.1 S, r.6.

**1.2 Transmission of documents**

- .1 Transmit the required documents.
  - 1. Transmit to the Parks Canada Engineer, to the CSST and to the Joint Health and Safety Association of the construction sector (ASP Construction) the prevention program specific to the construction site, as described in section 1.7, at least five (5) days before the start of work. The Contractor shall subsequently update its prevention program if the course of the work differs from its initial projections.
  - 2. The Engineer may, after receiving the program and/or at any time during the proceedings, require the program to be amended or supplemented to reflect the reality of the site. The Contractor must make the necessary corrections before the work begins.
  - 3. Transmit to the Engineer, the duly completed inspection of the site schedule at the frequency indicated in Article 1.12 of this section.
  - 4. Transmit to the Engineer, within twenty four (24) hours, a copy of any inspection report, correction notice, or recommendations issued by the federal or provincial inspectors.

5. Transmit to the Engineer, within twenty four (24) hours, an investigation report for any accident resulting in injury or on any incident that highlights a potential risk.
    6. Transmit to the Engineer all specification sheets (MSDSs) for controlled products used in the construction, and at least three (3) days prior to their use on site.
- .2 Transmit, to the Engineer, the copies of training certificates that are required for approval of the prevention program, including :
  1. Health and Safety on Construction Sites;
  2. Security Officer Certification;
  3. Workplace First Aid and CPR;
  4. Personal Protective Equipment at Work;
  5. Any other required training.
- .3 Medical Exams
  - .1 When medical examinations are required, under an Act, regulation, directive, a specification or a prevention program, the Contractor shall:
    1. prior to mobilization, transmit to the Engineer, the certificates of medical examinations of his supervision staff and all employees covered by the first paragraph of this article and who will be present at the opening of the construction site;
    2. transmit thereafter progressively and without delay, the medical examination certificates of all newcomers to the site that are covered by the first paragraph of this article.
- .4 Emergency Plan
  - .1 The emergency plan, as described in section 1.7, must be submitted to the Engineer together with the prevention program.
- .5 Site Opening Notice
  - .1 The site opening notice must be sent to the Commission of Health and Safety Labour before the work begins, with a copy to the Engineer. A copy of the notice must be prominently displayed on



the site. During demobilization, the notice of the site closure shall be transmitted to the CSST, with a copy to the Engineer.

.6 Work Permits

- .1 The Contractor shall obtain any municipal, provincial and federal permits that are in accordance with the contract requirements. Copies of the applications for permits and licenses must be sent promptly to the Engineer.

.7 Plans and Compliance Documents

- .1 The Contractor shall transmit to the CSST and the Engineer, a copy signed and sealed by an engineer of all plans and compliance documents that are required under: Safety Code for Construction (S-2.1, r .6), another law, another regulation or other provision of the specifications or contract. A copy of these documents must be available at all times on site.

**1.3 Identification of hazards related to working methods, equipment and facilities**

- .1 The Contractor shall conduct a hazard identification relating to each of the tasks performed on site.
- .2 The Contractor shall plan and organize work so as to promote the elimination of hazards at the source or a collective protection and thus minimize the use of personal protective equipment. Where personal protection against falling is required, workers must use a safety harness in accordance with CAN / CSA-Z259.10 standard. The use of security belts is forbidden. Wearing a life jacket may also be required.
- .3 Equipment, tool or means of protection which cannot be installed and used without compromising the health and safety of workers or the public is deemed inadequate for the job.
- .4 All mechanical equipment should be inspected before their delivery to the site. Before the use of mechanical equipment, the Contractor shall send, to the Engineer, a certificate of compliance signed by a qualified mechanic. The Engineer may at any time, if he suspects a defect or safety hazard, order the immediate halt of the equipment and require a second inspection by an expert of his choice.
- .5 There should not be imposed, on any part of the structure, a load which could damage it. In addition, all construction activities on the bridge must be approved by the Engineer.

**1.4 Health and Safety Meetings**

- .1 A decision representative of the Contractor shall attend all meetings where health and safety issues on the site are discussed.
- .2 The Contractor shall establish a project committee and hold meetings as required by the Safety Code for the construction work.

**1.5 Legal and regulatory requirements**

- .1 Comply with all laws, all regulations and all standards that are applicable to the performance of the work.

**1.6 Specific site conditions related to the location**

- .1 On this site, you need to consider the following particularities:
  1. Constant presence of the public (pedestrians, cyclists) nearby the construction site ;
  2. Lachine Canal Waterway - passage of pleasure boats.

**1.7 Health and Safety management**

- .1 Accept and assume all the duties and obligations normally assigned to the prime contractor under the Health and Safety at Work Act (RSQ, chapter S-2.1) and the Safety Code for the construction work (S- 2.1 r.6).
- .2 Develop a prevention program specific to the site that is based on the identification of risks and implement this program from the beginning of the project until the final stage of demobilization. The prevention program should consider the information that appears in section 1.6. It must be sent to all concerned, in accordance with Article 1.2. The prevention program must include at least the following :
  1. The company's Health and Safety policy;
  2. The description, the total cost, the schedule and the projected manpower curve of the work;
  3. The organizational health and safety responsibilities diagram;
  4. The physical and material organization of the construction site;
  5. The first response and first aid standards;



6. The identification of risks in relation to the site;
7. The identification of risks related to the tasks performed, including preventive measures and implementation arrangements;
8. The required training;
9. The procedure in case of accident/injury;
10. The written commitment of all stakeholders to respect this prevention program;
11. An inspection chart of the site based on preventive measures.

.3 Emergency plan :

1. The Contractor shall develop an effective emergency plan in relation to the characteristics and constraints of the site and its environment.
2. The emergency plan must be sent to all concerned, in accordance with Article 1.2.
3. The emergency plan must particularly contain the following :
  - .1 The evacuation procedure ;
  - .2 Identification of resources (police, fire department, ambulance, etc.) ;
  - .3 Identification of the persons managing the site ;
  - .4 Identification of rescuers ;
  - .5 The training required for those responsible for its implementation ;
  - .6 Any other information that would be required, given the characteristics of the site.

**1.8 Responsibilities**

- .1 Regardless of the size of the construction site or the number of workers present, appoint a competent person as supervisor and manager for Health and Safety. Take all necessary measures to ensure the health and safety of people and property at work and in the immediate vicinity of the site which could be affected by the progress of the work.
- .2 Take all necessary measures to ensure the implementation and enforcement of health and safety requirements contained in the

contractual documents, the federal and provincial regulations, the standards which are applicable and the specific site prevention program and immediately comply with any corrective measure issued by the Commission on Health and Safety at Work.

- .3 Take all necessary measures to keep the site clean and tidy throughout the work.

### **1.9 Communications and postings**

- .1 Take all necessary steps to ensure effective communication of health and safety information on the site. Upon arrival at the site, all workers must be informed of the particulars of the prevention program, their obligations and their rights. The Contractor must insist on the right of workers to refuse to perform work if they believe that this work can jeopardize their health, safety, physical integrity or that of other people on the site. The Contractor must keep on site and update a register with the information transmitted and the signature of all workers who have received this information.
- .2 The information and the following documents must be posted in an easily accessible place for workers :
  - 1. Site opening notice;
  - 2. Identification of the main contractor;
  - 3. Company policy on occupational health and safety;
  - 4. Site's specific prevention program;
  - 5. Emergency plan;
  - 6. Safety Data Sheets of all controlled products used in the construction;
  - 7. Minutes of meetings of the Construction Committee;
  - 8. Names of representatives to the site committee;
  - 9. Names of rescuers;
  - 10. Intervention reports and correction measures issued by the CSST.

**1.10 Unforeseen events**

- .1 When a source of danger, not indicated in the specifications and not identifiable during the preliminary inspection of the site, appears out of or during the performance of the work, the Contractor shall stop work immediately, implement temporary protective measures for workers and the public and advise the Engineer verbally and in writing. The Contractor must then make the necessary changes to the prevention program for that work to resume safely.

**1.11 Health/Safety/Hygiene Manager**

- .1 Name, from the outset of the work, a safety officer, in accordance with Articles 2.5.3 and 2.5.4 of the Safety Code for Construction (S-2.1, r.6) and grant him the authority and resources necessary for the performance of his duties.
- .2 Appoint early in the contract a competent person whose task is to ensure compliance and enforcement of all laws, regulations and standards as well as contractual requirements for health and safety.
- .3 The successful candidate will specifically:
  1. Have a thorough knowledge of the laws and regulations applicable to the site in terms of occupational safety and health;
  2. Develop and disseminate an awareness program for all employees of the construction site;
  3. Ensure that no worker is allowed on site without taking the awareness program training and meeting the requirements in accordance with the applicable legislation and the specific prevention program at the site;
  4. Inspect the work and ensure compliance with all regulatory requirements and those indicated in the contract documents or the prevention program;
  5. Keep a daily record of his actions and send a copy to the Engineer once a week.

**1.12 Inspection of workplaces**

- .1 Inspect workplaces and complete the construction inspection form at least once a week.
- .2 Promptly take all necessary actions to correct derogations from the laws and regulations and hazardous situations that are identified by a government inspector, the Engineer, the Health and Safety Coordinator or during periodic inspections.
- .3 Send to the Engineer a written confirmation of any measures taken to correct derogations and hazardous situations.
- .4 Shutdown :

1. The security officer or the person appointed to take care of health and safety shall order stopping and resumption during dangerous situations. This person must ensure that the health and safety of the public and site personnel always have precedence over issues related to cost and schedule.
2. Without limiting the scope of sections 1.7 and 1.8, the Engineer may at any time order the work stopped if, in his perception, there is a danger or a risk to the health or safety of site personnel or the public or the environment.

**PART 2 – PRODUCTS****2.1 Protection against falls**

- .1 Safety Guardrails :
  1. The guardrail installation is mandatory. Parks Canada may indicate some restrictions on anchoring, in which case, the Contractor shall ensure that guardrails still comply with all the requirements of section 3.8 of the Safety Code for the construction industry (RSQ, S-2.1, r.6).
  2. Guardrails must remain in place until the end of the project. The Engineer will authorise dismantlement when he can confirm that all work, all inspections and any required corrections have been made.

**.2 Harness :**

1. Wearing a safety harness is mandatory for the installation of the safety guardrails;
2. Wearing a safety harness is mandatory for the installation and modification of platforms and when it is necessary to temporarily move the guardrails;
3. Wearing a safety harness is mandatory for the reception of materials and for the signals to the crane operator when located along the canal and the bridge;
4. Wearing a safety harness is mandatory for all work at height where collective protection does not provide adequate safety;
5. The Contractor shall submit the attachment method and the backup cable system in compliance with section 2.10.12 of the Safety Code for the construction industry (RSQ, S-2.1, r.6) for each different sector or work location.

**.3 Ladders :**

1. All ladders should be of sufficient length to exceed the access landing by at least three (3) rungs;
2. All ladders must be attached at the top so as not to slide sideways. The Contractor shall implement a system to enable to continue to enforce this rule during the finishing work.

**.4 Scaffoldings :**

1. All scaffoldings must be assembled and inspected in accordance with the Safety Code for the construction industry (RSQ, S-2.1, r.6);
2. Plans and scaffolding related compliance documents must be submitted to the Engineer before the beginning of the work;
3. When assembling scaffolding, the Contractor shall ensure that all workers are constantly protected against falls, in accordance to Article 3.9.4.5 of the Safety Code for the construction industry (RSQ, S 2.1, r .6).

**2.2 Material lifting**

- .1 For all lifting equipment, the Contractor shall transmit, to the Engineer, a mechanical inspection certificate. The inspection done just before the delivery of the equipment on the site.
- .2 In addition to the mechanical inspection certificate, all cranes and truck cranes shall carry, in the cabin, the annual inspection certificate and the crane's logbook.
- .3 The lifting equipment must be positioned so that the loads are not transported over the heads of workers, occupants and the public.
- .4 The whole lifting area must be barricaded to prevent any unauthorized person to enter.
- .5 The Contractor shall obtain all permits and pay the costs, if it is necessary to temporarily block the public highway, in order to respect the preceding paragraph or for any other reason concerning the safety of workers, occupants or the public.
- .6 The Contractor shall carefully inspect all slings and lifting accessories and to ensure that those that are in poor condition are destroyed and scrapped.
- .7 The lifting of the compressed gas cylinder must be done with a basket specially designed for this purpose.

**2.3 Protection against fire**

- .1 Work on construction sites shall conform to the standard of the Fire Commissioner of Canada CI 301, June 1982. The text for this standard can be found on the Internet at the following address:

<http://info.load-otea.hrdc-drhc.gc.ca/prevention-incendies/normes/301.shtml>

**2.4 Materials and wastes management**

- .1 Lightweight materials and sheet materials should be kept off the bridge in containers or firmly attached. Storage of materials on the bridge is prohibited.
- .2 The preceding paragraph also applies to waste.
- .3 Waste must be evacuated as they are generated and by appropriate containers.
- .4 All waste must be removed from the bridge at the end of a shift.

- .5 Unless by special permission of the Engineer, any waste dumpster must be placed at least three (3) meters from any structure or building.

**2.5 General protection and site organisation**

- .1 Regardless of the circumstances and nature of work, people with access to the site shall wear safety footwear and headgear. The Contractor shall provide, to workers who have to crouch or bend the chin, chin protection or ratchet suspensions.
- .2 The platforms shall be installed as to prevent debris from falling into the canal.
- .3 The area of ground work and materials handling area shall be barricaded, so that occupants and the public cannot access.
- .4 Before installing any equipment or device likely to emit gases or vapors, the Contractor must obtain authorization from the worksite safety manager. This will ensure that there is no risk of infiltration into the ventilation systems of the surrounding buildings.
- .5 The Contractor must ensure that the site is kept clean and tidy throughout the work.
- .6 Copies of material safety data sheets of all controlled products must be sent to the Engineer and worksite safety manager before the beginning of work.
- .7 The Contractor shall provide sanitary facilities and rest areas consistent with the Safety Code requirements for construction works.

**END OF SECTION**





**PART 1 - GENERAL****1.1 Compliance with laws and regulations**

- .1 The Contractor shall be required to comply with all provincial, municipal or federal regulations and any other Act or any laws relating to these works. The Contractor shall be required to assume responsibility for any violation of the relevant laws and regulations. Without limitation, the following laws and regulations will be the subject of special attention, namely:
  - .1 The National Parks Act;
  - .2 The Fisheries Act;
  - .3 The Environmental Protection Act.
- .2 In addition to complying with laws and regulations stipulated in the preceding paragraph, the Contractor shall comply with the mitigation measures listed in Appendix 1 of this section.

**1.2 National Parks Act**

- .1 All works to be performed within the park boundaries, must be in accordance with the provisions of the National Parks Act.

**1.3 Fisheries Act**

- .1 The Fisheries Act (FA) stipulates, among other things :
  - .1 Article 35 (1) - that all projects undertaken in aquatic environments should not result in net loss of fish habitat or decrease in fish productivity or disruption or destruction of fish habitat;
  - .2 In Article 36 (3) – that it is prohibited to reject harmful substances into waters where fish inhabit;
  - .3 In Article 38 (4) – that it is mandatory to report any case of spill of harmful substances into waters inhabited by fish.

**1.4 Environmental Protection Act**

- .1 The Environmental Protection Act (CEPA) stipulates, among other things :
  - .1 In Article 95 (1) – that it is mandatory to report any case of spill of Toxic Substances (Annex 1 of CEPA) in the environment.

**1.5 Construction site**

- .1 Trucks and all machinery must be in good working condition to avoid any leakage of oil, grease and fuel. The equipment emitting a sound level or the exhaust gases above normal will have to be repaired or altered to make them acceptable.
- .2 General maintenance and fueling of equipment and vehicles as well as handling and storage of hydrocarbons will be made at a distance of more than thirty (30) meters from the bank of the canal.
- .3 The movement of heavy vehicles and the use of noisy machinery will be limited as much as possible.
- .4 In order to comply with the Federal Sustainable Development Strategy and to raise awareness about the importance of responsible behavior, the Contractor shall ensure that the machinery used is respectful to the environment. For example, machinery producing greenhouse gases (vehicles, heavy machinery, generator, etc.) shall not run unnecessarily.

**1.6 Fires**

- .1 Fires and the burning of wastes on the site are forbidden.
- .2 When fires and burning of wastes is permitted, prevent soiling or damage caused by smoke to works, constructions and materials, as well as to the vegetation that must be preserved. Clean and rehabilitate soiled or damaged structures.
- .3 Take the necessary measures to ensure the monitoring and protection against fire, as instructed.

**1.7 Waste disposal**

- .1 It is forbidden to bury wastes and waste materials on site, unless expressly approved by the Engineer.
- .2 It is forbidden to evacuate waste materials or contaminant materials such as mineral spirits, oil or paint thinners, paint and waste oils, by pouring them into the neighboring waterway, storm sewers or sanitary sewers.
- .3 The Contractor is responsible to ensure that no debris falls into the Lachine Canal.
- .4 Evacuate off-site all wastes and excess materials in a landfill approved by the relevant authorities and by the Engineer.
- .5 Provide a document to the Engineer stating the place of disposal of wastes and excavation materials, and certifying it is approved.

**1.8 Drainage**

- .1 The Contractor shall provide temporary drainage and pumping required to keep excavations and site free from water.
- .2 It is prohibited to reject, without the appropriate filtration system, any water containing sediments or suspended matter into the waterway, sewer systems or drainage systems.
- .3 Check the drainage and runoff of water containing suspended particles of materials or other deleterious substances, as required by current regulations.
- .4 Obtain approval by the Engineer, of any method or proposed system to control the discharge of waste water from work.
- .5 The Engineer may require the Contractor to provide, at his own expense, changes to the method or wastewater control system that he proposes if these do not meet the minimum standards of reject quality in the environment.

**1.9 Works carried out near a body of water**

- .1 Respect the laws mentioned in this section.

**1.10 Pollution prevention**

- .1 Maintain temporary facilities to prevent erosion and pollution and implemented under the present contract.
- .2 Ensure control of gases from equipment and facilities in accordance with the requirements of the regulations in effect.
- .3 Build temporary shelters to prevent the blasting materials and other foreign matter from contaminating the air beyond the area of application.
- .4 Wet down dry materials and cover the wastes to prevent the wind to raise dust and debris. Eliminate and remove any dust from temporary roads.
- .5 Provide onsite availability of absorbent products in sufficient quantities to be able to cleanup any spill of contaminants such as hydrocarbons, solvents and other similar products.

**1.11 Site cleanup and plant protection**

- .1 Not applicable.

**1.12 Storage and handling of petroleum products**

- .1 The storage and handling of petroleum products (gasoline, motor oil and hydraulic oil) on the site may present risks of spillage. To minimize these risks, all protective measures to minimize the risk of spills are to be adopted. The Contractor shall have a minimum of equipment.
- .2 Handle petroleum products and any other contaminant carefully, on land and in an appropriate area; Carefully store and appropriately arrange for disposal.
- .3 Provide emergency measures to adopt in case of equipment failure or accidental spillage. See to repair any defective equipment in the shortest possible time. In case of an accidental spill, quickly contain and recover the spilled product, clean the area and the contaminated equipment, move the contaminated soil to an authorized site and restore the affected area.

**1.13 Installation and removal of a temporary jetty**

- .1 Not applicable.

**1.14 Management and resuspension of sediments**

- .1 Not applicable.

**1.15 Contaminated soils**

- .1 Soils to be excavated at approaches are considered contaminated
- .2 Anticipated contamination level meets criteria "B-C" according to MDDELCC chart.
- .3 The Contractor is responsible for excavation procedures, the site layout and the disposal at an authorized site.
- .4 These methods and procedures shall comply with MDDELCC requirements.
- .5 Contaminated soil management is paid at item 4.1 described in "01290-Measurement for Payment".

**ANNEXE 1 – Mitigation and residual impacts**

Summary Table – Sir-George-Étienne-Cartier Pedestrian Bridge Rehabilitation Project – Lachine Canal Measures and Residual Impacts

Item/Activity of Project	Environmental Components	Description of Environmental Impacts	Mitigation Measures	Scale of Residual Impacts
1. Use and circulation of machinery/Transportation of materials and equipment/Storage  Mobilization/Demobilization	Air quality	<ul style="list-style-type: none"> <li>Decline in air quality caused by particle emission (dust)</li> <li>Machinery emits CO<sub>2</sub></li> </ul>	1.1 Make sure equipment and vehicles are inspected, clean and in good operating condition 1.2 Do not run engine when vehicles are stopped 1.3 Make sure materials that are being transported are covered 1.4 If needed, cover stored materials (whose fine particles could be carried by the wind) with a tarpaulin 1.5 Comply with existing municipal regulation regarding dust emission (Regulation 90 of the Communauté métropolitaine de Montréal) 1.6 Avoid handling and transporting material that can easily erode during periods of high winds or when dust plume is visible 1.7 Implement appropriate measures for the reduction of dust emission in the area (e.g. wetting, sweeping, using tarpaulins, etc.)	Negligible highly localized residual impact
	Noise level	<ul style="list-style-type: none"> <li>Increase in ambient noise level</li> </ul>	1.8 Comply with existing municipal regulation regarding noise level and work schedule 1.9 Effectively manage site as to minimize work that causes significant noise levels	None once work is completed
	Water and soil quality	<ul style="list-style-type: none"> <li>Soil compaction in mobilization area (if applicable)</li> <li>Risk of hydrocarbon spill (or other hazardous substances) in soil or water</li> </ul>	1.10 Make sure machinery and equipment operate properly for all duration of work. Repair or remove from site leaking vehicles or equipment at once 1.11 Machinery being operated on riverbanks or water must be equipped with a hydraulic system using biodegradable vegetable oil 1.12 Do not store fuel, oil, lubricant or other petrochemicals, less than 30 metres from any body of water. Place them on impervious tarpaulins 1.13 Have adequate quantity of oil recovery emergency kits at all times during work (oil retention barriers, absorbent rolls, tight containers, etc.). Make sure workers are trained in responding to leaks or spills.	Negligible highly localized residual impact

Item/Activity of Project	Environmental Components	Description of Environmental Impacts	Mitigation Measures	Scale of Residual Impacts
	Vegetation	<ul style="list-style-type: none"> <li>Damage to vegetation and grassy area</li> </ul>	<p>1.14 Plan an emergency procedure and a communication protocol in case of environmental incident</p> <p>1.15 In case of land-based spill, notify appropriate responders and the National Environmental Emergencies Centre (1-866-283-2323) at once</p> <p>1.16 Prevent, retain, contain, and clean spills and leaks at once</p> <p>1.17 Avoid refuelling machinery less than 30 metres from a body of water</p> <p>1.18 Implement sediment and erosion control measures if soil is disturbed or exposed</p> <p>1.19 Avoid operating vehicles during heavy rain periods when soils are saturated with water</p> <p>1.20 Machinery must NEVER circulate on the bed of the canal</p> <p>1.21 Favour the mobilization/circulation of vehicles on durable surfaces (e.g. pavement)</p> <p>1.22 Limit worksite and storage area to durable surfaces</p> <p>1.23 Rehabilitate to initial conditions land surfaces and vegetation damaged during work</p> <p>1.24 Rehabilitated surfaces shall present a degree of compaction and aeration which corresponds to the initial conditions (before work) as to prevent transportation and circulation of soil particles</p> <p>1.25 Comply with additional requirements from Project Manager and Site Supervisor</p> <p>1.26 When brought on site, make sure machinery is clean and free of invasive species and weeds. Maintain the machinery in this state afterwards. At the end of work, properly clean machinery in contact with exotic invasive species as to prevent dispersion in new areas</p>	Negligible highly localized residual impact
2. Concrete demolition and reconstruction (deck, walls and abutments) Demolition and installation of a	Air, water and soil quality	<ul style="list-style-type: none"> <li>Transportation of particles, materials and construction debris on soil and in aquatic habitat</li> <li>Particle emission</li> </ul>	<p>2.1 Clean construction waste as it is created and dispose of in MDDELCC authorized sites</p> <p>2.2 Do not throw away waste or residue in the body of water</p> <p>2.3 Provide measures as to confine and recover</p>	Negligible highly localized residual impact

Item/Activity of Project	Environmental Components	Description of Environmental Impacts	Mitigation Measures	Scale of Residual Impacts
new metal deck		during welding work	<p>concrete and steel waste, as well as weld splatter (e.g. tarpaulin, geotextile, sediment barrier which is ballasted or anchored parallel to the bank, plateforme étanche, etc.). Make sure to limit the movement of residues in the body of water when removing the installations</p> <p>2.4 Do not take borrow material from the body of water</p> <p>2.5 Concrete excess from concrete mixers must be poured in moulds, or any other type of tight container. Concrete residues must be handled with construction waste</p> <p>2.6 Try to reduce welding work to a minimum</p> <p>2.7 Make sure residual and cleaning water is confined and recovered. If a treatment system must be used (portable settling basin, filters or similar installations), it must prevent the runoff of contaminants and sediments in sewer systems and bodies of water. Employ necessary means to establish the method of disposal of sediments collected and residual water, and to make sure applicable standards regarding discharge are complied with</p>	Negligible
3. Painting of structure	Aquatic fauna  Air, water and soil quality	<ul style="list-style-type: none"> <li>• Disruption/stress for various fish species</li> <li>• Encroachment on habitat</li> <li>• Risk of water contamination if paint deteriorates with time and reaches surface water</li> <li>• Risk of paint spill</li> <li>• Sprayed paint particles in the air</li> </ul>	<p>2.8 Limit work area as much as possible to prevent potential impacts (dust, waste, etc.) on fish habitat</p> <p>2.9 Use catch measures to minimize transportation of sediments/waste</p> <p>2.10 No encroachment is allowed on the body of water as to prevent loss of fish habitat</p> <p>3.1 Implement protection measures as to prevent dispersion of paint particles (or other coating), such as: - Avoid high wind periods - Properly set the spray gun's flow rate - Use screens to minimize loss caused by overspray</p> <p>3.2 Do not use products composed of prohibited substances under the Canadian Environment Protection Act or pursuant regulation</p>	Negligible

Item/Activity of Project	Environmental Components	Description of Environmental Impacts	Mitigation Measures	Scale of Residual Impacts
4. Excavation, backfilling			<p>3.3 Use products that will have the least harmful effects on the environment. Make sure of their environmental compliance</p> <p>3.4 Dispose of paint and paint/solvent mixtures in accordance with applicable federal, provincial and municipal legislation. It is forbidden to dispose of paint or paint/solvent mixtures on site.</p>	
	Water and soil/sediment quality	<ul style="list-style-type: none"> <li>• Soil and surface water contamination via cross contamination</li> </ul>	<p>4.1 Process excavated soils in accordance with applicable federal, provincial and municipal laws and regulations in regard to the management of contaminated soils</p>	Insignificant: temporary and small residual impact
	Aquatic habitat	<ul style="list-style-type: none"> <li>• Erosion</li> </ul>	<p>4.2 Limit in situ storage time of excavated materials</p>	
	Health	<ul style="list-style-type: none"> <li>• Contamination of backfill via adjacent soils</li> <li>• Sediment transportation</li> <li>• Contamination and loss of habitat (siltation and alteration of seabed)</li> </ul>	<p>4.3 Store contaminated soils in accordance with MDDELCC recognized standards. Take necessary precautions to prevent contamination of underlying and adjacent soils, at least:</p> <ul style="list-style-type: none"> <li>- Separate soils in accordance with their level of contamination, or depending on observed stratigraphy</li> <li>- Store soils on plastic tarpaulin or geotextile and cover; or store soils in tight containers. Tarpaulins must be firmly anchored so that they are not lifted by the action of wind</li> </ul>	
			<p>4.4 Put soils back in place as quickly as possible in accordance with levels of contamination initially observed or with initial stratigraphic profile</p>	
		<p>4.5 At any time, make sure soils do not migrate towards other environments (by air, runoff or vehicles)</p>		
		<p>4.4 If required, soil characterization must be carried out on excess excavated soils as to establish the degree of contamination and properly manage their disposal</p>		
		<p>4.5 Contaminated excavated soils shall be stored, transported and disposed of off-site in accordance with</p>		



Item/Activity of Project	Environmental Components	Description of Environmental Impacts	Mitigation Measures	Scale of Residual Impacts
			<p>the provisions of the MDDELCC Policy</p> <p>4.6 When disposing of soils off-site, keep every document or slip certifying of the disposal in MDDELCC authorized sites in accordance with their degree of contamination</p> <p>4.7 If surface soil must be restored, install a geotextile membrane between in-situ contaminated soils and the new material</p> <p>4.8 Soil imported on Parks Canada property must be terre de culture which complies with the latest standards of the City of Montreal and the <i>Bureau de normalisation du Québec</i></p> <p>4.9 Use clean backfill material (prevent introducing material contaminated by substances present in the original environment, by particles, or invasive species)</p> <p>4.10 New material (e.g. topsoil, controlled backfill material) must be properly compacted to prevent sag and minimize erosion</p> <p>4.11 Avoid excavation work during heavy rain periods</p> <p>4.12 Comply with particular requirements established by Parks Canada regarding archaeological monitoring. In case archaeological monitoring is not required for work and that archaeological remains (construction or facility remains, object and fragments of object) are discovered by chance, the Contractor must stop work in the immediate sector and notify Parks Canada Representative who shall take the necessary measures to protect and preserve the remains</p> <p>4.13 Implement efficient measures to limit transportation of sediments from the worksite to the aquatic habitat and ensure their maintenance (e.g. sediment barrier, berms, sediment traps, settling basin, temporary stabilization of slopes, diversion of water towards vegetation areas). Measures must remain efficient when site is temporarily closed or during heavy rain or flood periods</p> <p>4.14 Measure 2.7</p>	
5. Cleaning/surface stripping	•	Transportation of	Comply with municipal regulation in force regarding	Insignificant:

Item/Activity of Project	Environmental Components	Description of Environmental Impacts	Mitigation Measures	Scale of Residual Impacts
(grinding, sandblast)	Air quality and health Water and soil/sediment quality Aquatic habitat	contaminated substances in environment <ul style="list-style-type: none"> <li>• Emission of dust, paint and silica particles</li> <li>• Particles containing silica can cause serious intoxication problems for exposed worker</li> </ul>	dust emission 5.2 Implement appropriate containment and recovery measures to minimize contaminants in air and soils. For example: 5.3 Install enclosure and collecting tank to hold paint and sandblasting particles. The enclosure must be impervious to prevent leaching in case of rain and be equipped with a ground catchment mechanism to prevent discharge in canal 5.4 Avoid work during high wind and dry weather periods 5.5 Process sandblasting waste as hazardous residual materials (HRM), as provided in the <i>Regulation respecting hazardous materials</i> Q-2, R.32 5.6 Implement appropriate measures to: <ul style="list-style-type: none"> <li>- Recover all sandblasting residues</li> <li>- Hermetically store residues</li> <li>- Dispose of residues in MDDELCC authorized sites</li> </ul> 5.7 Comply with accepted levels of silica in sandblasting abrasive specified in applicable regulation 5.8 Comply with provisions of <i>Clean Air Regulation</i> Q-2, r.4.1. 5.9 Refer to Regulation respecting the quality of the work environment, S-2.1, r.11, and Regulation respecting occupational health and safety, S-2, r.13 5.10 Whenever possible, use an abrasive which will cause fewer impacts than silica 5.11 Use required protective clothing (mask, gloves, etc.) depending on estimated exposure to dust	temporary and small residual impact

END OF SECTION

## PART 1 - GENERAL

### 1.1 Requirements

- .1 Unless otherwise indicated, use of new equipment and materials.
- .2 Within three (3) days of the written request of the Engineer, submit the following information for all materials and products to be used:
  1. The name and address of the manufacturer;
  2. The trademark, model and catalog number;
  3. The performance, description and test results;
  4. The manufacturer's instructions on installation or application;
  5. The evidence that they will be obtained.
- .3 Provide and install materials and equipment of prescribed design and quality, with a performance in line with established standards and for which there are readily available spare parts.
- .4 Unless otherwise specified, use products from a single manufacturer in the case of materials and equipment of the same type or the same class.

### 1.2 Manufacturer's instructions

- .1 Unless otherwise indicated, comply with the latest manufacturer's written instructions concerning the materials and equipment to be used and installation methods.
- .2 Notify the Engineer in writing of any discrepancy between these specifications and the manufacturer's instructions; the Engineer will determine which document to use.

### 1.3 Delivery and storage

- .1 The materials and equipment must be delivered and stored so as to keep intact the seal and the manufacturer's label.
- .2 Ensure that materials and equipment are not damaged, soiled or altered during delivery, handling and storage. The materials and equipment refused are to be transported off site immediately.

- .3 Store materials and equipment in accordance with the supplier's instructions.
- .4 Resurface, to the satisfaction of the Engineer, any damage to factory's finished surfaces. Use a primer or enamel in harmony with the original finish. Do not paint the identification plates.

**1.4 Compliance to standards**

- .1 If materials or equipment are prescribed under descriptive or performance standards, obtain from the manufacturer at the request of the Engineer, the report of an independent testing laboratory certifying that the materials or equipment meet or exceed the specified requirements.

**1.5 Substitution**

- .1 Substitution proposals should not be made prior to the contract award. Requests must be accompanied by a statement of the respective costs of the items specified in the tender and those proposed as alternatives.
- .2 The Engineer will take these requests into consideration only if:
  - 1. The products chosen by the bidder from those prescribed in the tender are not available, or if;
  - 2. The date of delivery of the products selected from those prescribed in the tender unduly delay the work, or;
  - 3. The products offered as substitutes are regarded, by the Engineer, as the equivalent of the prescribed products and their use result in a decrease in the contract price.
- .3 If the proposed substitution has been accepted in whole or in part, assume the full responsibility and the costs that could result from this substitution on other work. Pay the costs of changes to the design or drawings as a result of this substitution.
- .4 All the money saved as a result of the approved substitutions will be determined by the Engineer and the contract price will be reduced accordingly. No substitution will be allowed before the Engineer has granted his written approval.

**1.6 Construction equipment and tools**

- .1 Upon request, prove to the satisfaction of the Engineer, that the construction equipment and tools are adequate for the manufacture, transport and implementation of a finished product meeting the quality and production rates specified.

- .2 Maintain construction equipment and tools in good working condition.
- .3 The Contractor shall ensure, throughout the construction period, the use of equipment and the storage of his materials so as to respect the capacity of the bridge shown in the drawings.
- .4 The Contractor shall also ensure not to leave any equipment or machinery on the bridge outside of working hours.

**END OF SECTION**



**PART 1 - GENERAL**

**1.1 General requirements**

- .1 Perform the cleaning and disposal according to the local ordinances and the laws against pollution.
- .2 Remove the volatile waste, in covered metal containers, out of the site every day.
- .3 Ensure good ventilation during the use of volatile or toxic substances.

**1.2 Cleaning during construction**

- .1 Keep the construction site clean and the public properties free of debris and waste.
- .2 Remove waste and debris from the site.

**1.3 Final cleaning**

- .1 When the bridge repair work is almost completed, proceed to the inspection all exposed surfaces.
- .2 Remove grease, dust, dirt, labels, fingerprints and other foreign material from exposed finished surfaces, including concrete and asphalt surfaces.
- .3 Proceed to the cleaning of the work area. Restore the site to its original state and to the satisfaction of the Engineer.

**END OF SECTION**





**PART 1 - GENERAL**

**1.1 Shop drawings**

- .1 The Engineer will provide two (2) sets of positive copies of drawings to include to the project records.
- .2 Keep the drawings and faithfully note all deviations from the requirements of the contract documents, the changes imposed by the nature of the site and the changes ordered by the Engineer.
- .3 Enter the changes in red.
- .4 Record the following informations :
  1. Changes made to the dimensions and details of execution on site;
  2. Changes made following the reception of requested changes and orders received on site.
- .5 Once the work is complete and before the final inspection, carefully transcribe the corrections on the second set of drawings and hand the two (2) complete sets to the Engineer.

**END OF SECTION**



## PART 1 – GENERAL

- .1 The Engineer will provide two (2) copies of the drawings to be added to the project records.

### 1.1

- .1 Section 01561 – « Environmental protection »

### 1.2 References

*(Current Editions)*

- .1 Federal laws and regulations of Canada.
  - 1. Canadian Environmental Protection Act (CEPA).
  - 2. Canadian Environmental Assessment Act (CEAA).
  - 3. Transportation of Dangerous Goods Act (TDG).
  - 4. Motor Vehicle Safety Act (LSVA).
- .2 Canadian Standards Association (CSA)
  - 1. CSA S350- M1980, Code of Practice for Safety in Demolition of Structures.

### 1.3 Measurement for payment

- .1 The costs incurred for partial demolition of the slab are included in the price of the items entitled « Slab concrete demolition » and « Backwall demolition » whose payment terms are described in section « 01290 - Measurement for payment ».

### 1.4 Existing conditions

- .1 If materials resembling asbestos materials, applied with a trowel or by spraying, or any other controlled substance are discovered during the execution of the work, the latter must be stopped, appropriate preventive measures must be taken and the Engineer must be informed on the spot. Do not resume work before having received written instructions regarding this.
- .2 The elements to be demolished are identified in the drawings. All these elements become the property of the Contractor.

**1.5 Demolition drawings**

- .1 Submit to the Engineer for approval, drawings, diagrams or details indicating the order of demolition, as well as items used for this work.
- .2 The drawings must be stamped and signed by a professional engineer registered or licensed to practice in Canada, in the province of Quebec.

**1.6 Protection mesures**

- .1 Take the necessary measures to prevent displacement, sagging or damage to the bridge structure during construction period. Supply and install the parts necessary for bracing and shoring. If necessary, repair the damaged structures during the demolition work as directed by the Engineer.
- .2 Secure required work platforms and shelter under the structure of the bridge and, if it appears that the demolition work constitute a danger for users of the Lachine Canal, take appropriate precautionary measures, stop work and notify the Engineer.
  1. Perform work as specified in section « 01561 - Environmental Protection ».
- .3 Ensure that the demolition debris does not fall into the Lachine Canal. All concrete fragment (or any other kind) that falls into the canal must be removed by the Contractor at his own expense.
- .4 Ensure that the demolition work produces no harmful effect on wildlife, groundwater and the Lachine Canal, and that they do not generate excessive atmospheric and noise level pollution.
- .5 It is forbidden to burn wastes and materials on site.
- .6 If demolition debris fall on the working platform, ensure that it is not overloaded by the weight of the debris.
- .7 Do not pour waste or volatile materials, such as mineral spirits, oils, petroleum based lubricants or toxic cleaning solutions in the Lachine Canal or the surrounding storms and sanitary sewers. Ensure the enforcement of appropriate methods of disposal of such wastes during the whole construction period.
- .8 Do not pour water containing suspended solids in the Lachine Canal, storm or sanitary sewers or on adjacent land either by pumping or otherwise.
- .9 If appropriate, ensure the drainage and containment of runoff waters containing suspended materials or other harmful substances, as required by local authorities.

- .10 Protect vegetation (trees, plants, shrubs and foliage) on the site and that of the adjacent properties, as directed by the Engineer.
- .11 Prevent substances or foreign matter from contaminating the air outside the site by erecting temporary protective enclosures during the execution of demolition.
- .12 Cover the dry materials and wastes or wet to prevent the uprising of dust and debris. Apply a dust suppressant on all temporary access roads.

**1.7 Documents/samples to submit**

- .1 The Contractor shall ensure compliance with all requirements for the transmission of documents, samples and reports on waste management, and this, to the satisfaction of the Engineer.
- .2 Before beginning the work, submit a detailed plan to reduce waste showing the projected percentages of reused, recycled and landfilled, the selective demolition plan, the nature and quantities of materials to be recovered, the number and location of recovery bins, the expected frequency of collection, and the name and address of the waste management centers.
- .3 Provide, at the Engineer's request, certified copies of receipts issued by landfills and reuse and recycling centers authorized for all materials removed from the site. Obtain the written permission of the Engineer before sending materials elsewhere than to waste management centers identified in the waste reduction plan.

**1.8 Regulatory requirements**

- .1 Ensure that the work is performed in accordance with all applicable provincial regulations.

**1.9 Meetings**

- .1 Hold a meeting before the beginning of the demolition work.
- .2 Ensure the presence of all key personnel and site supervisor.

**1.10 Scheduling**

- .1 Make sure that the schedule is respected, without compromising the prescribed minimum percentages of reused and recycled materials. Notify the Engineer in writing of any possible delays.

**PART 2 - PRODUCTS****2.1 Material and equipment**

- .1 The equipment and heavy machinery should be operated in order to meet or exceed the requirements of all relevant standards for emissions.
- .2 Shutdown machinery engines at the end of their use, unless extreme temperature conditions require uninterrupted operation.
- .3 Maximum overload indicated on drawings must be respected at all times.

**PART 3 - EXECUTION****3.1 Preparatory works**

- .1 Install working platforms under the structure. These platforms allow safe access to the work team and prevent demolition debris from falling into the Lachine Canal.
- .2 The Contractor must submit a plan signed and sealed by a member engineer of the Ordre des Ingénieurs du Québec. He must also submit a certificate of conformity signed by the same engineer.
- .3 The Contractor must ensure at all times not to obstruct the passage of pleasure boats during the navigable period.

**3.2 Security**

- .1 Perform demolition work within the requirements of section « 01545-Safety Measures ».
- .2 It is forbidden to resort to blasting for the execution of the demolition work.
- .3 Take all necessary precautions to prevent damage to the structural elements to be preserve.
- .4 Ensure that access to the pedestrian bridge is barricaded during the construction period.

**3.3 Demolition**

- .1 Demolish the slab of the pedestrian bridge, as well as the metal decking as shown in the drawings.
- .2 Execute all the demolition works necessary to enable the indicated work.
- .3 Place the stockpiled materials in a designated area as directed by the Engineer.
- .4 Provide separate waste containers and clearly labeled them for each category of waste materials.
- .5 At the end of each working day, make sure that the structure is safe and stable. Protect at all times, against the elements, the surfaces of the parts that will not be demolished.
- .6 Perform the demolition work in order to lift as little dust as possible, and keep materials wet as directed by the Engineer.
- .7 Dispose of materials as directed by the Engineer.
- .8 Unless otherwise notified, remove and dispose of construction demolition materials, respecting the requirements of the competent authorities.
- .9 Environmental Protection
  1. Remove the materials defined as hazardous or contaminated by the competent authorities for environmental protection, and dispose of it out of the site by taking all the necessary security measures to minimize the dangers during their removal and disposal.
- .10 Perform work in daylight as often as possible. At the end of each working day, close all light sources except those used for security purposes. Follow local regulations regarding noise control for the work.

**3.4 Reports**

- .1 From the information recorded on the weighing slips, transmit the following data to the satisfaction of the Engineer :
  1. Description of materials ;
  2. Quantity of evacuated materials ;
  3. Ventilation of quantities of reused, recycled and landfilled materials ;
  4. Final destination of evacuated materials.

**3.5 Coordination**

- .1 The Contractor shall ensure that all requirements for the coordination of waste management are met to the satisfaction of the Engineer.

**END OF SECTION**



## PART 1 – GENERAL

### 1.1 Related sections

- .1 Section « 03200 – Concrete reinforcement »
- .2 Section « 03300 – Cast-in-place concrete »
- .3 Section « 03301 – Concrete for bridge deck »
- .4 Section « 01340 - Shop drawings, Product and Sample Descriptions »
- .5 Section « 01561 - Environmental Protection »

### 1.2 Measurement for payment

- .1 For all formworks, no measurement will be made under this section. Include the relevant costs in the lots of concrete work which require the use of concrete forms.
- .2 The costs relating to the supply and installation of work platforms are included in the prices of the item entitled "Work platforms and shelter", whose payment terms are described in section « 01290 Measurement for payment ».

### 1.3 Description

- .1 The main works covered by this section are as follows:
  - 1. Preparation of shop drawings illustrating formwork as well as work platforms and method of installation
  - 2. Installation and removal of formwork and work platforms needed.
- .2 The work also includes all related works required for the completion of these structures in accordance with drawings and specifications

### 1.4 References

*(Current Editions)*

- .1 Canadian Standards Association (CSA)
  - 1. CAN/CSA-A23.1 / A23.2, Concrete - Materials and Construction/Test methods and standard practices for concrete;
  - 2. CAN/CSA-A23.3, Design of concrete structures;

3. CAN/CSA-O86.1, Engineering Design in Wood to limit states;
  4. CAN/CSA-O86S1 Supplement No. 1 to CAN/CSA-086-01, Engineering Design in Wood.
  5. CSA O121, Plywood Douglas fir.
  6. CSA O151, Plywood Wooden Canadian softwood.
  7. CSA O153 Poplar Plywood.
  8. CSA O437-series F93, Standards for oriented strand board and waferboard.
  9. CSA S269.1, Falsework for Construction Purposes.
  10. CAN / CSA-S269.3, Formwork, National Standard of Canada.
  11. CAN/CSA-S16, Steel Structures calculation rules.Council of Forest Industries of British Columbia (COFI)
- .2 COFI, Exterior Plywood for Concrete Formwork.

### **1.5 Shop drawings**

- .1 Submit shop drawings of the formwork and work platforms in accordance with the requirements of section « 01340 - Shop drawings, Product and Sample Descriptions ».
- .2 Shop drawings must indicate, show or include the construction method and schedule of the work, the procedures regarding working platforms, formwork removal, materials, specific geometrical characteristics of the finished exposed surfaces, the provision of the transversal joints, rods and liners, and the location of the temporary recessed parts. Comply with the CSA S269.1 standard in regards to the drawings of temporary shoring works. Comply with CAN/CSA-S269.3 standard in regards to the formwork drawings.
- .3 Shop drawings must indicate the formwork design data such as the speed and the temperature eligible for the implementation of concrete into the formworks.
- .4 Specify the order of assembly and dismantling of formworks and temporary work platforms, as directed by the Engineer.

- .5 Each consignment shop drawings must be stamped and signed by a professional engineer registered or licensed to exercise in Canada, in the province of Quebec.

## **1.6 Waste management and disposal**

- .1 Separate and recycle waste materials in accordance with the requirements of section « 01561 - Environmental Protection » and the requirements of the wastes reduction plan.
- .2 Place in designated containers substances that meet the definition of hazardous or toxic waste.
- .3 Ensure that emptied containers are sealed and stored safely, out of the reach of children, until proper disposal.
- .4 Use stamping products, formwork release agents and non-toxic mold release oils, biodegradable and with zero or low VOC content.

## **PART 2 - PRODUCTS**

### **2.1 Materials**

- .1 Formwork Materials
  - 1. Use wooden formworks and wood products in compliance with the CAN/CSA-O86.1, CAN/CSA-A23.1 and CAN/CSA S269.3 standards.
- .2 Formwork Tie-Rods
  - 1. Formwork tie-rods shall consist of steel bars with a diameter greater than 10 mm.
  - 2. Minimum capacity of vertical formwork ties shall be 40 kN in service; ties shall be 19 mm in diameter (except for high-strength steel ties such as DYWIDAG or equivalent, which must be at least 15 mm). "Snap tie" type tie rods are prohibited. When the reinforcement layer adjacent to the formwork is composed of galvanized steel, the corresponding ends of formwork ties or tie rods shall be made of hot-dipped galvanized steel. The layer of zinc on ties shall be between 50 and 87 µm.
- .3 Formwork Lining
  - 1. Plywood : Douglas fir in compliance with CSA Standard O121 of 17.5 mm minimum thickness.

- .4 Formwork Release Agent
  - 1. Release agent: non-toxic and biodegradable.
- .5 Mold Release Oil
  - 1. Mold release oil: colorless mineral oil, non-toxic, biodegradable, low VOC, kerosene free.
- .6 Temporary shoring structures
  - 1. Materials for temporary shoring works : in compliance with CSA-S269.1 standard.

## **PART 3 - EXECUTION**

### **3.1 Construction and installation**

- .1 Fabricate and install formworks in accordance with the CAN/CSA-S269.3, in order to obtain concrete finished works in the form, dimensions and level consistent with the indications and situated where indicated; within the tolerances prescribed in CAN/CSA-A23.1 standard.
- .2 Before undertaking the construction of formworks and temporary work platforms, validate the lines, levels and distances, and make sure that the dimensions correspond to those indicated on drawings.
- .3 Fabricate and install temporary shoring structures in accordance with the CSA S269.1 standard and the Exterior Plywood for Concrete Formwork guide by COFI.
- .4 Align formwork joints and make them watertight. Minimize the number of joints.
- .5 Unless indicated otherwise, use 25 mm chamfer strips for sharp edges and/or 25 mm baguettes for internal angles of formwork joints.
- .6 The grooves, slots, openings, eaves, nip-points and expansion and control joints must conform to indications.
- .7 Incorporate anchors, sleeves and other embedded parts required for the works specified in other sections. Ensure that all those embedded parts do not protrude onto surfaces to be coated with a finish, for example, a coat of paint.
- .8 Obtain approval of the Engineer before casting concrete directly into the ground or create, in the formworks, openings that are not shown in the drawings.

- .9 Before pouring the concrete directly into the ground, clean the sides and bottom of the excavated area, and then remove any loose soil.
- .10 Before pouring the concrete, clean the formworks in accordance with the CAN/CSA-A23.1 standard. In addition, all reinforcement must be in place prior to concreting.
- .11 Before concreting, the design engineer of the Contractor shall conduct an inspection of all the formworks in the presence of the Engineer. The design engineer must provide and sign a written certificate of conformity stating its acceptance of the complete installation of formworks, including the cleaning of the bottom sections of the formworks.

**3.2 Formworks and temporary access platforms removal**

- .1 The Contractor shall not remove the formworks and their supports or braces before obtaining the permission of the Engineer.
- .2 Formworks are considered to be removed when they are loosened and at least a portion of them is no longer in contact with the concrete.
- .3 After placing the concrete, leave the formworks in place for at least the appropriate time period indicated below :
  - 1. Seven (7) days for the repair of the deck slab.
- .4 Reuse formworks and temporary shoring works, subjected to the requirements of the CSA-A23.1 / A23.2 standard.

**END OF SECTION**



**PART 1 – GENERAL****1.1 Related requirements**

- .1 Section 03100 – Formworks for concrete, temporary work platforms and accessories
- .2 Section 03300 – Cast-in-place concrete

**1.2 Measurement for payments**

- .1 The costs relating to the supply and installation of reinforcement are included in the price of the item entitled « galvanized Reinforcement » whose payment terms are described in « 01290 - Measurement for payment ».

**1.3 References**

*(Current Editions)*

- .1 Ministère des Transports
  - 1. Cahier des charges et devis généraux (CCDG) ;
  - 2. MTQ – Tome VII – Matériaux – Ouvrages routiers (MTQ – Tome VII – Materials – Road Structures)
- .2 American Concrete Institute (ACI)
  - 1. SP-66, ACI Detailing Manual.
- .3 ASTM International
  - 1. ASTM A 82/A 82M, Standard Specification for Steel Wire, Plain, for Concrete Reinforcement ;
  - 2. ASTM A 123/A 123M, Standard Specification for Zinc (Hot-Dip Galvanized) Coatings on Iron and Steel Products. ;
  - 3. ASTM A 143/A 143M, Standard Practice for Safeguarding Against Embrittlement of Hot-Dip Galvanized Structural Steel Products and Procedure for Detecting Embrittlement ;
  - 4. ASTM A 185/A 185M, Standard Specification for Steel Welded Wire Reinforcement, Plain, for Concrete ;
  - 5. ASTM A 497/A 497M, Standard Specification for Steel Welded Wire Reinforcement, Deformed, for Concrete.

- .4 Canadian Standards Association (CSA)/CSA International:
  - 1. CSA A23.1 /A23.2-, Concrete Materials and Construction / test methods and standard practices for concrete;
  - 2. CAN / CSA-A23.3- Design of concrete structures;
  - 3. CAN / CSA S6 - Calculation of road bridges;
  - 4. CAN / CSA-G30.18, Carbon Steel Bars of Concrete Reinforcement;
  - 5. CAN / CSA-G40.20 / G40.21, General Requirements for Rolled or welded steel construction / Structural steel;
  - 6. CAN / CSA-G164, hot galvanizing of irregularly shaped objects;
  - 7. CSA W186 welding rebar in reinforced concrete structures.
- .5 Canadian Institute of reinforcing steel (RSIC / IAAC)
  - 8. IAAC-2004, Reinforcing steel, recommended standards manual.

#### **1.4 Shop drawings**

- .1 Submit the required shop drawings, showing the location of the reinforcement bars, as specified in « 01340 - Shop Drawings, product and sample descriptions ».
- .2 Indicate on the shop drawings, the rebar list required, the necessary number of elements and rebar and the folding details of the last two, the dimensions, spacing and location of the reinforcement bars as well as the necessary mechanical splices if their use is approved by the Engineer. The rebars which are shown in the shop drawings are to be marked by an identification code to be able to place them correctly without consulting the structural drawings. The drawings must also indicate the size, spacing and location of the bar chairs, spacers and supports. The reinforcement bars designs must be executed in accordance with the Manual of Recommended Standards, published by the Canadian Institute of reinforcing steel.
- .3 Unless otherwise specified, overlap lengths and bar development lengths must comply with the CAN/CSA-A23.3 standard.



**1.5 Waste management and disposal**

- .1 Separate and recycle waste materials in accordance with the requirements of section « 01561 - Environmental Protection » and the requirements of the wastes reduction plan.

**PART 2 - PRODUCTS****2.1 Materials**

- .1 Any replacement of reinforcement bars by one of different dimensions must be authorized in writing by the Engineer.
- .2 Reinforcement Bars
  1. Les barres d'armature en acier doivent être pliées après galvanisation et avant leur mise en place suivant les formes exactes indiquées aux dessins. L'Entrepreneur doit prendre soin de bien vérifier les mesures de pliage et de s'assurer que les dégagements par rapport au coffrage sont respectés.
  2. All new reinforcement bars shall be high-bonded ribbed bars in compliance to CAN/CSA G30.18 standard, 400W grade, unless otherwise indicated on the drawings.
  3. Steel reinforcement bars shall be bent after galvanization and prior to installation, in accordance with the exact shapes indicated on the drawings. The Contractor shall take great care to properly verify the bending measurements and ensure that formwork clearances are respected.
- .3 Anchors
  - .1 Anchors shall be manufactured from 400W grade of high adhesion reinforcing steel, in compliance with the CAN/CSA G30.18 standard and shaped in accordance with the CAN/CSA A23.1 / A23.2 standard.
  - .2 The reinforcement bars, anchored in the existing concrete by means of a chemical resin or non-shrink grout, must withstand theoretical pull-out strength of 15 kN.
- .4 Wire Ties
  1. All wire ties are to be cold-drawn annealed steel in compliance with the STM A82/A82M standard.

2. Galvanized wire ties is used with galvanized reinforcing steel.

.5 Bar chairs, spacers, bar and shim supports

1. All bar chairs, spacers and bar and shims supports must comply with the CAN/CSA-A23.1 standard. These elements must be protected against corrosion.
2. It is forbidden to use wood blocks, bricks or stones as a shim or bar support.

.6 Mechanical splices

1. Mechanical splices shall be subject to the Engineer's approval.

**2.1 Protective coating**

.1 Galvanized protective coating of non-prestressed reinforcement, minimum zinc coating of at least  $610 \text{ g/m}^2$ , in compliance with the CAN/CSA-G164 standard.

1. Protect galvanized reinforcing steel with chromate treatment to prevent any reaction with Portland cement paste;
2. If chromate treatment is carried out immediately after galvanizing, soak reinforcing steel in aqueous solution containing a minimum of 0.2% by weight of sodium dichromate or 0.2% of chromic acid;
3. The temperature of the solution must be equal to or greater than 32 degrees and the galvanized reinforcing steel immersed for at least a minimum of twenty (20) seconds;
4. If the galvanized reinforcing steel are at ambient temperature, add sulphuric acid as a bonding agent. Sulfuric acid concentration must be between 0.5% to 1%.
5. In this case, no restriction applies to the temperature of the solution;
6. Chromate solution sold for this purpose may replace the solution described above, provided it is of equivalent effectiveness;

- .2 The straight galvanized reinforcing bars that were factory cut may be delivered to the site under the condition that the cut ends were factory coated by paint brush with a zinc-rich coating (such as "Zinga" or approved equivalent) at least 130  $\mu\text{m}$  thick.

## **2.2 Shaping**

- .1 Unless otherwise indicated, the steel reinforcement bars should be formed in accordance with the CAN/CSA-A23.1 / A23.2 standards, the SP-66 standard, and the Handbook of Recommended Standards, published by the Canadian Institute of reinforcing steel.
- .2 The Engineer must approve the location of joints other than those indicated on implementing drawings.
- .3 Once they are approved by the Engineer, the reinforcement bars must be welded in accordance with the CSA W186 standard.
- .4 The electrodes used for welding must comply with the CAN/CSA W48 standard, E480XX of classification.
- .5 The reinforcement bars lot shipments must be clearly marked by an identification code in accordance with the list of required reinforcement bars and their bending details.

## **2.3 Quality control at source**

- .1 At least one (1) week prior to the implementation of the reinforcement bars, submit to the Engineer, a certified copy of the tests report that have been made at the factory, describing the results of physical and chemical analyzes of the reinforcement steel.
- .2 Inform the engineer of the proposed source of supply for the materials to be supplied.

## **PART 3 - EXECUTION**

### **3.1 Preparation**

- .1 Galvanizing of reinforcement bars must include a chromate treatment. Duration of the treatment is to be determined by the bar diameter, namely one (1) hour per 25 mm of diameter.
- .2 Make the bend tests to verify the fragility of galvanized rebar in accordance with the ASTM A 143/A 143M standard.

**3.2 Bending on site**

- .1 Unless otherwise specified or authorized by the Engineer rebar should not be bent or welded on site.
- .2 When field bending is authorized, bend without heat, applying slow and steady pressure.
- .3 Replace reinforcement bars that show evidence of cracks or splits.

**3.3 Reinforcement bars placement**

- .1 Reinforcement steel must be free of sludge, coating oil or any other substance that could hinder the bond to the concrete.
- .2 Place reinforcement steel as indicated on placement drawings and in accordance with the CSA-A23.1/A23.2 standards.
- .3 Reinforcing bars that intersect must be solidly connected to one another at every intersection if the intersections are spaced more than 300 mm apart, and at every other intersection if spacing is less.
- .4 All tie wires used to connect reinforcing bars to one another must be folded toward the inside in a manner to ensure thickness of concrete cover is not decreased.
- .5 Prior to pouring concrete, obtain the Engineer's approval of reinforcing material and placement.
- .6 Ensure coverage of reinforcement bars is maintained during concrete cast.

**3.4 Anchor placement**

- .1 The anchors must be installed using epoxy resin according to the manufacturer's instructions. The anchor bars, drilled holes and resin cartridges must have compatible diameters between them.
- .2 The resin blend must completely fill the anchor holes. For overhang anchors, the necessary precautions must be taken to prevent the loss of material by gravity.
- .3 The data sheets for the resins and the method of implementation, including the equipment used, must be submitted to the Engineer for review and comment at least fourteen (14) days before the anchor installation work.
- .4 When the ambient temperature is below 5° C or the minimum temperature specified by the manufacturer, the epoxy resin cartridges must be stored in a heated area, to be implemented at a temperature

between 10° C and 25° C and the anchoring rods must be pre-heated immediately prior to being installed.

- .5 The holes can be drilled using percussion and rotary drills, hole size must match the dimensions specified by the manufacturer of the anchors. The holes must be cleaned of debris produced by drilling by means of a jet of compressed air.
- .6 The anchors should not suffer any effort for a period of twenty-four (24) hours of their installation and should not be touched or moved during the initial setting of the resin.

### **3.5 Touch-ups on site**

- .1 Using a consistent finished product, retouch the damaged or cut ends of the galvanized reinforcement, so as to obtain a continuous coating.

### **3.6 Cleaning**

- .1 Leave the premises clean at the end of each working day.
- .2 Once the work is completed, evacuate from the site the surplus materials, rubbish, tools and equipment.
- .3 Separate waste materials for recycling.

**END OF SECTION**



**PART 1 – GENERAL****1.1 Related requirements**

- .1 Section 03100 – Formworks for concrete, temporary work platforms and accessories
- .2 Section 03200 – Concrete reinforcement
- .3 Section 03301 – Concrete for bridge deck

**1.2 Measurement for payment**

- .1 Costs related to concrete work are included in the prices of the items entitled « Concrete for slab », « Concrete - backwall », the terms of payment are described in section « 01290 - Measurement for payment ».

**1.3 References**

*(Current Editions)*

**Abbreviations et acronyms**

- .1 Portland Cement : hydraulic cement or hydraulic cement compound (where « b » suffix indicates that this is a composite product).
  - 1. Type GU, GUb or GUL: general purpose cement;
  - 2. Type MS or MSb: moderate strength cement to sulphates;
  - 3. Type MH, MHL or MHb: moderate hydration heat cement;
  - 4. Type HE HEB or HEL: high early strength cement;
  - 5. Type LH, LHb or LHL: low heat of hydration cement;
  - 6. Type HS or HSb: high sulfate resistance cement.
- .2 Fly ash
  - 1. Type F: having a calcium oxide content of less than 15%.
  - 2. Type S: having a calcium oxide content of between 15 and 20%.

3. Type HP: having a calcium oxide content of 20%.
  4. Type S: granulated blast furnace slag.
- .3 American Society for Testing and Materials (ASTM)
1. ASTM C109/C109M, Test Method for Compressive Strength of Hydraulic Cement Mortars (Using 2 in. or 50 mm Cube Specimens).
  2. ASTM C 260/C 260M, Standard Specification for Air-Entraining Admixtures for Concrete.
  3. ASTM C 309, Standard Specification for Liquid Membrane-Forming Compounds for Curing Concrete.
  4. ASTM C332, Specification for Lightweight Aggregates for Insulating Concrete.
  5. ASTM C 494/C 494M, Standard Specification for Chemical Admixtures for Concrete.
  6. ASTM C827, Test Method for Change in Height at Early Ages of Cylindrical Specimens from Cementitious Mixtures.
  7. ASTM C939, Test Method for Flow of Grout for Preplaced-Aggregate Concrete.
  8. ASTM C 1017/C 1017M, Standard Specification for Chemical Admixtures for Use in Producing Flowing Concrete.
  9. ASTM D 412, Standard Test Methods for Vulcanized Rubber and Thermoplastic Elastomers-Tension.
  10. ASTM D 624, Standard Test Method for Tear Strength of Conventional Vulcanized Rubber and Thermoplastic Elastomer.
  11. ASTM D 1751, Standard Specification for Preformed Expansion Joint Filler for Concrete Paving and Structural Construction (Nonextruding and Resilient Bituminous Types).
  12. ASTM D 1752, Standard Specification for Preformed Sponge Rubber Cork and Recycled PVC



Expansion Joint Fillers for Concrete Paving and Structural Construction.

- .4 Canadian Standards Association (CSA)
  - 1. CAN/CSA-A5, Portland Cements.
  - 2. CSA A23.1/A23.2, Concrete Materials and Construction / Test methods and standard practices for concrete.
  - 3. CAN/CSA-A23.2, Test for Concrete.
  - 4. CAN/CSA-A23.5, Supplementary Cementing Materials.
  - 5. CSA A283 Qualification Code for Concrete Testing Laboratories.
  - 6. CAN/CSA-A363, hydraulic slag cement.
  - 7. CSA A3000, Compendium binder materials (Contains A3001, A3002, A3003, A3004 and A3005).

#### **1.4 Samples**

- .1 Submit at least five (5) days before the beginning of concrete work, the samples required in accordance with section « 01340 - Shop Drawings, product descriptions and samples ».
- .2 At least one (1) week prior to undertaking the work, notify the Engineer of the proposed supply source for aggregates, and allow him to have access for sampling.

#### **1.5 Certificates**

- .1 Submit the required certificates as specified in section « 01340 - Shop Drawings, product descriptions and samples ».
- .2 The Engineer may require the Contractor to submit samples of the adjuvants he intends to use.
- .3 At least one (1) week prior to the beginning of the concrete work, submit to the Engineer copies of the test reports that have been made by the manufacturer and a certificate issued by an independent and qualified testing and inspection laboratory and certifying that the materials listed below shall conform to requirements :

1. Portland cement;
  2. Hydraulic cement compound;
  3. Cement additives;
  4. Admixtures;
  5. Aggregates;
  6. Water.
- .4 Provide a certificate attesting that the selected dosage formula will produce concrete of the quality, durability and performance prescribed, and is in accordance with the requirements of the CAN/CSA-A23.1 standard. In case of any divergence or any discrepancy from the formula or dosing parameters prescribed for the concrete mixture, do not continue work without first obtaining the written permission of the Engineer.
- .5 Provide proof that the mixing plant, the equipment and the materials to be used for the manufacturing of the concrete meet the requirements of the CAN/CSA-A23.1 standard.

**1.6 Quality Assurance**

- .1 Submit to the Engineer at least five (5) days before the beginning of the concrete work, a valid certificate issued and recognized by the factory providing the concrete.
- .2 Provide the technical sheet of the curing materials to the Engineer.
- .3 At least one (1) week prior to the beginning of the concrete works, submit for the approval of the Engineer, the methods proposed to control the quality of the following tasks :
1. Erection of access platforms and formworks;
  2. Concreting in hot weather;
  3. Concreting in cold weather;
  4. Cure;
  5. Finish;
  6. Removal of formworks.

**1.7 Transport, storage and handling**

.1 Delivery and acceptance

1. Transit time

- .1 Concrete must be delivered to the construction site and unloaded within a maximum of one hundred and twenty (120) minutes after the mixing.
- .2 If applicable, any changes to the maximum transport time must be accepted in writing by the Engineer and producer of concrete, as indicated in the CSA A23.1/A23.2 standards.
- .3 The time differences must be submitted to the Engineer for review.

2. Delivery of concrete

- .1 Make sure the concrete plant ensures continuous concrete delivery in accordance with the CSA A23.1/A23.2 standards.

**1.8 Waste management and disposal**

- 1. Sort and recycle waste materials as prescribed in section « 01561 - Environmental Protection » and the requirements of the waste reduction plan.
- 2. Provide trigger sprayers to connect to water hoses.
- 3. Designate a cleaning area to limit the consumption of clean water and the volume of surface runoff.
- 4. Carefully coordinate the prescribed concrete works depending on weather conditions.
- 5. Ensure that empty containers are sealed and stored, in a safe place and out of reach of children, for disposal.
- 6. Take the necessary precautions to prevent plasticizers, water reducers or air entraining agent, used in making concrete, from contaminating rivers and the sources of drinking water. If applicable, collect the liquid or solidify with an inert non-combustible material, taking all appropriate safety measures. Dispose of all wastes in

accordance with the local, provincial and national applicable requirements.

7. Choose the least damaging method of cleaning which nevertheless will get the best possible results.

## **PART 2 - PRODUCTS**

### **2.1 Materials**

#### **.1 Cement et cement additives**

1. Hydraulic cements must comply with the CAN/CSA A23.1 and CAN/CSA A3000 standards.
2. The cementitious binder used should be composed of a hydraulic cement of the GUb-SF, GUb-S/SF, or GUb-F/SF type.
3. The total mass of cementitious materials (fly ash, finely ground granulated slag of blast furnace and silica fume) must not exceed 30% of the total mass of the binder.
4. Silica fume shall comply with the CAN/CSA A3000, U-type standard.
5. Fly ash, when required, must comply with the requirements of the CAN/CSA A3000, F-type standard and specifically to the section of the A3001 standard - Binders used in concrete.

.2 Water

1. The water used for the mixing and curing of concrete must be fresh, clean, potable and free of oil and chemical or organic impurities, and must comply with the provisions of section 4 of the CAN/CSA Standard A23. 1 standard.

.3 Aggregates

1. All aggregates must be clean, resistant and free of harmful substances, and must meet the requirements of the CAN/CSA A23.1 standard applicable to the appropriate exposure class.

.4 Admixtures

1. Air entraining admixtures

- .1 The air entraining admixtures must comply with the ASTM C260 standard.

2. Chemical admixtures

- .1 The chemical admixtures must comply with the ASTM C494/C494M or ASTM C1017/C1017M standards.
- .2 The Engineer shall approve the accelerators or retarders used for concrete setting in cold weather or hot weather.

.5 Curing products

1. The materials used in the curing of concrete must meet the requirements of the following standards: CSA A23.1/A23.2, ASTM C171, ASTM C309 and AASHTO M182.

**2.2 Dosage formula**

The characteristics as well as the concrete mix to be used in this project are defined in the following table.

Type	Resistance at 28 days (MPa)	Minimum binder Mass (kg/m <sup>3</sup> )	Type of binder <sup>(1)</sup>	Ratio water/binder max. or interval	Sagging (mm) ± 30	Large aggregates (mm)	Air content (%) <sup>(2)</sup>	Permeability to ions chloride max. (Coulombs)
V-S	35	340 365	GUb-SF GUb-F/SF, GUb-S/SF	0.38 to 0.42	130	5-14	5-8	1000

- (1) The GUb-SF-type binder should contain at least 8% silica fume.  
The GUb-F/SF and GUb-S/SF type binders must contain at least 5% of silica fume and at least 15% of fly ash or slag.  
The total mass of cementitious materials (fly ash, silica fume, slag) must not exceed 30% of the total weight of binder.
- (2) The air content must conform to the specifications mentioned in the table, whether or not adding superplasticizer.

**PART 3 - EXECUTION****3.1 Preparation**

- .1 Obtain approval of the Engineer before the concrete pouring and advise him twenty-four (24) hours in advance of the execution of this work.
- .2 Before the concrete pouring, obtain the authorization of the Engineer as to the proposed method to protect concrete during pouring and curing in bad weather.
- .3 Observe the following instructions during concrete works :
  1. It is prohibited to make cold joints;
  2. Ensure that the transport and handling of the concrete are made as to minimize the interventions during its implementation and not cause any damage to the structure or to other existing structures.
- .4 Protect existing structures against dirt.
- .5 The pumping of concrete will only be allowed once the equipment and mixture are approved.
- .6 Ensure that reinforcement bars and embedded parts are not moved during the concrete pour.
- .7 Clean concrete surfaces and remove stains before applying the finishing products.
- .8 Before pouring the concrete, obtain the authorization of the Engineer as to the method proposed to protect concrete during installation and curing.
- .9 Keep a record of concrete works accurately indicating the date and location of each concrete pour, the characteristics of the concrete, the ambient temperature and the samples taken.
- .10 In locations where new concrete is bonded to an existing structure, drill holes in the existing concrete, introduce steel studs made of high-adhesion steel rebars and secure them well with epoxy grout to anchor and maintain them at the indicated positions.
- .11 No charge should be applied to new concrete elements before the Engineer has issued an authorization.

### 3.2 Implementation

- .1 Proceed with cast-in-place concrete structure works in accordance with the CAN/CSA-A23.1 standard.
- .2 The pumped concrete should be placed in accordance with the requirements of the ACI 304.2R standard.
- .3 Finish
  1. Finish concrete surfaces in accordance with the CAN/CSA-A23.1 standard;
  2. Unless otherwise indicated, perform a finish with a vibrating screed.

### 3.3 Sleeves and embedded elements

- .1 After obtaining the permission of the Engineer, arrange the openings and place the sleeves, fasteners, hangers and other embedded items indicated on the drawings or specified elsewhere.
- .2 Sleeves and openings greater than 100 mm x 100 mm that are not indicated must be reviewed by the Engineer.
- .3 Do not remove or move rebars to install hardware parts. If the elements to be embedded in the concrete cannot be placed at indicated locations, obtain the written autorisation of the Engineer, for any changes, before pouring the concrete.
- .4 Confirm the location and dimensions of the sleeves and openings shown in the drawings.
- .5 Install special items to be embedded, for strength testing purposes, according to indications and requirements of the methods used for nondestructive testing of concrete.

### 3.4 Cure and finishing

- .1 Finish concrete surfaces according to the CSA A23.1/A23.2 standard.
- .2 To remove excess bleeding water, use methods revised to the satisfaction of the Engineer. Take every care not to damage the surfaces of the concrete elements.



- .3 For formed concrete surfaces, formwork tie rods and other metal parts must be removed or cut back to at least 40 mm from the concrete surface.
- .4 The holes left by tie rods, in-ground parts and cavities must be deep and have relatively perpendicular edges to hold the skim mortar compound.
- .5 It is prohibited to use water or other products to facilitate the concrete finishing.
- .6 Hollow areas and cavities must be saturated with water and repaired after brushing the irregular surface with pure cement paste and filling by means of a mortar containing the same type of sand and the same type of cement as those which have been used for the concrete.
- .7 Surfaces must be kept moist for a period of three (3) consecutive hours preceding the filling operation with concrete or mortar.
- .8 The mortar must be strongly pressed or compacted into the cavity so as to fill it completely, then the surface is finished to obtain the same texture as that of the adjacent surface.
- .9 Use curing compounds compatible with the finishing product applied to concrete surfaces. Provide a written statement establishing that the various products used are compatible.

### **3.5 Tolerances**

- .1 Tolerance of finishing of concrete surfaces will comply with the CAN/CSA-A23.1 standard, concrete finish straight rule method.

### **3.6 On-site Quality control**

- .1 The inspection and testing of concrete and its components will be carried out by a testing laboratory designated by the Engineer in accordance with the CAN/CSA-A23.1 standard.
- .2 The Engineer will bear the cost of testing.
- .3 The Engineer will take additional cylindrical specimens in concrete work in cold weather. The curing of these samples will have to be at the site, under the same conditions as the concrete pours from which they are taken.
- .4 Non-destructive testing of concrete shall be performed by the methods described in the CAN/CSA-A23.2 standard.

- .5 Inspection and testing done by the Consultant shall not replace or supplement the quality control performed by the Contractor, nor do they relieve the latter of its contractual responsibilities in this regard.

**END OF SECTION**

**PART 1 – GENERAL****1.1 Related sections**

- .1 Section 03100 – Formworks for concrete, temporary work platforms and accessories
- .2 Section 03200 – Concrete reinforcement
- .3 Section 03300 – Cast-in-place concrete

**1.2 Measurement for payment**

- .1 The costs relating to the supply and installation of reinforcement are included in the price of the items entitled « Concrete for bridge deck » whose payment terms are described in section « 01290 - Measurement for payment ».

**1.3 References**

*(Current Editions)*

- .1 Canadian Standards Association (CSA)
  - 1. CAN/CSA-A23.1, Concrete - Materials and work.

**1.4 Waste management and disposal**

- .1 Sort and recycle waste as prescribed in section « 01561 - Environmental Protection ».
- .2 Place in designated containers, substances that meet the definition of toxic and hazardous waste.
- .3 Ensure emptied containers are sealed and stored, safely out of the reach of children, for their disposal.
- .4 Designate a cleaning area for the tools in order to limit the consumption of water and runoff.
- .5 Make arrangements to prevent plasticizers, water reducers and air entraining agents in the concrete composition from contaminating streams or other sources of drinking water. If necessary, collect liquid or solidify those with non-combustible inert material by taking all appropriate safety measures. Evacuate and remove them as required by local, provincial and national regulations.

**PART 2 - PRODUCTS****3.1 Materials**

- .1 Dosages and concrete components : in compliance with the requirements of section « 03300 – Cast-in-place concrete ».
- .2 Reinforcement steel : meeting the requirements of section « 03200 – Concrete reinforcement ».

**PART 3 - EXECUTION****3.1 Implementation**

- .1 Execute concrete works as prescribed in section « 03300 - Cast-in-place concrete ».
- .2 Cast the concrete deck and finish it with a vibrating screed. The finishing method should allow to meet the finishing tolerances in section 3.3 of section « 03300 - Cast-in-place concrete ».
- .3 Ensure that the pace of the casting will enable to complete the concrete implementation, finish and cure envisaged in due time.
- .4 Make sure you have retained the services of experienced concrete finishing manpower.
- .5 Immediately before pouring the concrete, check formworks, and make necessary adjustments. Provide an appropriate means, eg indicators, to enable the Engineer to measure compaction and sagging.
- .6 Do not pour concrete over a larger area than it is possible to finish before the beginning of the initial setting.
- .7 Screeding the concrete surface immediately after the concrete has been poured and consolidated. Correct any adjustment or operation that does not immediately provides consolidation and a satisfactory uniforme finish. Unsatisfactory results may result in the rejection of the material used and the obligation to remove the concrete poured in place.
- .8 Use jitterbugs to remove minor roughness or irregularities left by the vibrating screed or finisher and seal the concrete surface, to the satisfaction of the Engineer.

**3.2 Protection**

- .1 Regarding the protection and curing of concrete cast between November 1<sup>st</sup> and December 20<sup>th</sup>, comply with the following requirements in addition

to those of the CAN/CSA-A23.1 standard, for the protection of concrete poured in cold weather. Note that the concrete slab cast is not recommended between December 21<sup>st</sup> and March 31<sup>st</sup>.

- .2 Protect the concrete using a windproof shelter, made of canvas or other material, and allowing the ambient air to circulate freely around the fresh concrete. The walls of the shelter must not, at any point, touch the formwork. Provide enough space to allow removal of formworks and to enable surface finishing. Use heating equipment approved by the Engineer. Ensure adequate ventilation allowing the evacuation of the combustion products to the outside of the shelter. Heating equipment must be able to maintain the ambient air at a sufficiently high and constant temperature so that the concrete maintains the following cure temperatures.
  1. During the three (3) days, the temperature on the surface of the concrete must not be less than 15° C nor above 27° C.
  2. For the slab, extend the curing period of concrete by seven (7) days, at a temperature of 10° C.
- .3 Keep continuously moist the concrete surfaces during the period in which the concrete is protected against the cold.
- .4 Surfaces Unformed: ensure the curing of the concrete using strips of burlap and water. Carefully place two (2) wet burlap layers on the concrete surface. Overlap each strip by at least 150 mm and secure them so that they are not moved by the wind. Keep strips in place and keep them wet for seven (7) days following the placement of concrete.
- .5 Protect metal surfaces throughout the construction period. Any damage to the paint by the Contractor, will be repaired at his own expense, to the satisfaction of the Engineer.

**END OF SECTION**



**PART I - GENERAL****1.1 Related requirements**

- .1 This section covers the work can be related to the following sections :
1. Section 03100 - Formworks for concrete, temporary work platforms and accessories
  2. Section 03200 - Concrete reinforcement
  3. Section 33000 - Cast-in-place concrete

**1.2 Measurement for payment**

- .1 The costs related to the manufacturing, the supply and the structural steel installation are included in the prices of the items entitled « Drain » and « Expansion joint » whose payment terms are described in section « 01290 Measurement for payment ».

**1.3 Description**

- .1 The main works (see plans) covered by this section are the following:
1. Installation of a new steel deck;
  2. Installation of steel angles (Type L178 x 102 x 9.5) with studs from each side of the deck along the length of the pedestrian bridge;
  3. Replacement of the expansion joints at both abutments of the pedestrian bridge.

**1.4 References**

*(Current editions)*

- .1 Ministère des Transports du Québec
1. MTQ – Cahier des charges et devis généraux (CCDG).
- .2 American Association for State Highway and Transportation Officials (AASHTO)
1. AASHTO Standard Specifications for Highway Bridges-17<sup>th</sup> edition.
- .3 ASTM International
1. ASTM A108 Standard Specification for Steel Bar, Carbon and Alloy, Cold-Finished;
  2. ASTM A123/A123M Standard Specification for Zinc (Hot-Dip Galvanized) Coatings on Iron and Steel Products;
  3. ASTM A325M, Standard Specification for Structural Bolts, Steel, Heat Treated 830 MPa Minimum Tensile Strength Metric;

4. ASTM A490M rev A, Standard Specification for High-Strength Steel Bolts, Classes 10.9 and 10.9.3, for Structural Steel Joints.
- .4 Canadian Standards Association (CSA)/CSA International
1. CSA G40.20 / G40.21, General Requirements for Rolled and welded steel construction / structural steels;
  2. CAN / CSA-G164 M92, hot galvanizing of irregularly shaped objects;
  3. CAN / CSA S6, Canadian Code on Highway Bridge;
  4. CSA S16-09, Design of Steel Structures (Calculation rules for steel structures limit state);
  5. CSA S269.1-1975 falsework for Construction Purposes;
  6. CAN / CSA W47.1-F03 Certification of Companies for Fusion Welding of Steel;
  7. CSA W48, Filler metals and associated materials for arc welding;
  8. • CSA W59, Welded Steel Construction (Metal Arc Welding);
  9. CAN / CSA Certification of Welding Inspectors W178.2;
  10. CAN3 Z299.3-F85, Quality Assurance Program - Category 3.
- .5 SSPC standards (Society for Protective Coatings) - Preparation of steel surfaces
1. SSPC-SP 06, Commercial Blast Cleaning;
  2. SSPC-SP 10, Near White Blast Cleaning.



**1.5 Administrative procedures**

- .1 Meetings prior to installation
  1. Hold a meeting, one (1) week before the beginning of the installation of the bearing system and expansion joints, with the Parks Canada representative which will mainly examine the following:
    - .1 Work requirements;
    - .2 Installation conditions and the bearings status;
    - .3 Work coordination with those executed by other specialty trades;
    - .4 The access equipment and temporary support;
    - .5 The manufacturer's written instructions regarding the installation and the terms of guarantee offered by the latter.
- .2 Before beginning the work, make arrangements with the Engineer to discuss the existing conditions surrounding the area where the planned work will be executed.
- .3 Hold meetings at the Engineer's request.
- .4 Ensure the presence of all key staff at these meetings.
- .5 In the event that dates and/or time of the scheduled meetings established at the time of contract award are changed, the Engineer will notify everyone concerned, in writing, twenty-four (24) hours before the new scheduled meeting.

**1.6 Expansion Joints**

- .1 At least fourteen (14) days prior to ordering material and to production of any components, the Contractor shall submit, to the Engineer for review, shop drawings, technical data sheets and material samples of each of the materials to be used for the contract, including all steel joint elements.
- .2 The Contractor may not make any modification to materials or construction details provided for shop drawings reviewed by the Engineer without the prior written permission of the latter.
- .3 Before preparing his shop drawings, the Contractor shall conduct a comprehensive and detailed construction site survey of all existing elements to determine their exact dimensions and validate the dimensions and position of mounting holes shown in the drawings. The Contractor shall make this verification at all places where the same detail applies.
- .4 If, following the detailed survey of the elements, the resulting dimensions are very different from those indicated on the drawings or if the actual conditions do not allow the execution of such work as shown on the

drawings and indicated in the specifications, the Contractor shall notify the Engineer, and follow his instructions.

- .5 The fact that the documents or items mentioned in the preceding paragraphs are reviewed by the Engineer does not relieve the Contractor of its responsibility under the Contract, including, but not limited to, his responsibility regarding the provision of materials and proper equipment, adoption of suitable methods of execution, ensuring a good quality of works and the implementation of adequate security measures.

### **1.7 Shop drawings, Product and Sample Descriptions**

- .1 Submit documents/samples required in accordance with section « 01340 - Shop drawings, Product and Sample Descriptions ».

### **1.8 Technical datasheets**

- .1 Submit required product technical datasheets and instructions and the manufacturer's documentation regarding steel construction. The technical datasheets must include product characteristics, performance criteria, physical size, finish and limitations.
- .2 Submit two (2) copies of technical datasheets (MSDSs) under the WHMIS requirements in compliance to sections « 01545 - Safety measures » and « 01561 – Environmental protection ».

### **1.9 Shop drawings**

- .1 The submitted shop drawings shall be stamped and signed by a professional engineer registered or licensed in Canada, in the province of Quebec.
- .2 Shop drawings must indicate all the details of forming and assembly, including factory made joints, cuts, notches, assemblies, drilling, pressure plates, threaded anchors, rivets and welds. Welds must be indicated using the symbols defined in CSA W59 standard.
- .3 The documents setting out the proposed welding methods must be approved by the Canadian Welding Bureau, and must bear the seal of the latter.

### **1.10 Work methods**

- .1 Submit a description of the working methods, the temporary reinforcements, the order of assembly and the proposed type of equipment for the assembly of structural steel elements, as well as the procedure used to support the pedestrian bridge for the replacement of the bearing devices.
- .2 The working methods must be signed and sealed by an engineer member of the Ordre des ingénieurs du Québec and the engineer who signed the documents must be present during the work. At the end of each step completed, he must provide a certificate confirming the stability of the

temporary works and mentioning, where appropriate, instructions or corrective measures to ensure the stability of the structures.

### **1.11 Transport, storage and handling**

- .1 Provide transportation, storage and handling of elements.
- .2 Provide and implement protective wedges for transportation, support and storage of the elements.
  1. During the shaping, transportation and installation, the necessary precautions must be taken so that existing structural elements are not damaged;
  2. Do not cut the edges of the elements;
  3. Do not subject the components to excessive stress.
- .3 Indicate the mass on items that weigh more than three (3) tons.
- .4 Protect the components in unpainted weathering steel, before installation, using a waterproof tarp.
- .5 Ensure that no part of the steel components come into contact with the ground.
- .6 At least seven (7) days before shipment of the elements, submit to the Engineer, the delivery schedule.

### **1.12 Quality Assurance**

- .1 For each steel element delivery, bolts, nuts, washers or anchor rods and, at least, fourteen (14) days prior to their use, the Contractor shall provide to the Engineer a certificate of conformity.
- .2 The steel elements certificate of conformity must contain the following information for each production batch :
  1. The name of the steel mill;
  2. The date and place of manufacture;
  3. The nominal dimensions;
  4. The grade;
  5. The category;
  6. The cast number;
  7. The results of the analysis, testing and quality control measures;
  8. The number of the production lot.
- .3 The certificate of conformity of bolts, nuts, washers and anchor rods must contain the following information for each production batch :
  1. The manufacturer's name;
  2. The date of manufacture;

3. The identification marking;
  4. The nominal dimensions;
  5. The steel grade;
  6. The category;
  7. The cast number;
  8. The analysis and tests results;
  9. Information on the coating;
- .4 The number of the production lot. - A production lot consists of the same type of construction steel pieces of the same color, same class, same size and from the same cast.
  - .5 Samples used for physical testing shall be obtained at the steel mill for their inspection by the Engineer.
  - .6 Preliminary tests prior to construction :
    1. Provide suitable facilities and collaborate with the agency responsible for the inspection and with the Engineer for the execution of the inspection and the tests required.

## PART 2 - PRODUCTS

### 2.1 Materials/Equipment

- .1 Structural steel elements must come from a Canadian or American steel company that holds a registration certificate that complies with the ISO 9001 quality management systems. The Contractor shall provide to the Engineer, at least two (2) weeks prior to the delivery of all structural steel elements to the construction site or at the manufacturing plant, the name of the steel mill.
- .2 All steel elements must be new and free of deformation, rust and defects such as cracks, notches or sharp edges.
- .3 Manufacturing and welding works must be performed by companies approved by the Canadian Welding Bureau in compliance to the CSA-W47.1 Division 1 standard.
- .4 Structural steel : in compliance to the CSA G40.20/G40.21, Type and Grade 300W and 350W standards.
- .5 All steel components are hot dip galvanized.
- .6 Hot dip galvanized nuts, washers and high strength bolts : in compliance to the ASTM A325M. Bolts that meet the ASTM A490M standard may be used, subject to the approval of the Engineer.
- .7 Hot dip galvanized anchor bolts, nuts and washers : in compliance to the CSA G40.20/G40.21, galvanized grade 300W steel standards.
- .8 The new metal deck to install is a steel P-3615 20 x 0.91 mm type provided by CANAM.

- .9 The new expansion joints to install are ZT-300HR, series 1000 type provided by GOODCO Z-TECH or equivalent approved by the Engineer.
- .10 Welding electrodes : in compliance to the CSA W48 standard.
- .11 Shearing connectors: in compliance to paragraph 5.5.6 of the CSA W59 standard.
- .12 Hot dip galvanizing : in compliance to the CAN/CSA-G164 standard, and ensuring a zinc coating of at least 600 g/m<sup>2</sup>.
- .13 Grout shrinkage compensation : mixture, prepared in advance, consisting of non-metallic granulate, Portland cement, plasticizing agents and water reducers.

**2.2 Quality control at the source**

- .1 Qualification of steel producer : certification to the CSA G40.20/G40.21 standard.
- .2 Provide suitable facilities and collaborate with the agency responsible for the inspection and the Engineer for the execution of the inspection and testing requirements.
- .3 Unless otherwise specified in the plans, welding examinations must be carried out by way of visual inspection on the reinforcement plates installed on the HSS and in compliance with the CSA W59 standard on 100% of the welds, and this, before, during and after welding.

**PART 3 - EXECUTION****3.1 Examination**

- .1 Condition verification : prior to the installation of structural steel elements, ensure that the condition of the surfaces/materials previously implemented under other sections or contracts is acceptable and enables to perform the work in accordance with manufacturer's written instructions.
- .2 Immediately inform the Engineer of all detected unacceptable conditions;
- .3 Begin the installation work only after correcting the unacceptable conditions and obtaining written approval of the Engineer.

**3.2 Preparation**

- .1 Shape and install the bearing elements as indicated.

**3.3 Installation**

- .1 Build temporary shoring works in compliance with the CSA S269.1 standard.
- .2 Shape and mount the structural steel elements according to the CAN/CSA S6, Canadian Code on the calculation of road bridges standard.

- .3 Welding : unless otherwise indicated, perform welding work in accordance with the CSA W59 standard.
  - 1. Perform shop welding, unless the Engineer authorizes, in writing, their execution elsewhere;
  - 2. Perform the welds only where indicated.
- .4 Finish : the elements must conform to prescribed alignments, and be free of twists, bends, open joints, sharp angles and edges.
- .5 The joints performed on site must be approved by the Engineer.
- .6 Mark structural steel elements according to the CSA G40.20/G40.21 standards.
  - 1. It is, however, prohibited to punch mark.
- .7 Assembly marks : mark, in shop, joints and support pieces for assembly purposes.
- .8 Protect the exposed surfaces of the concrete substructure against soiling caused by the surface finish of unpainted steel elements, as follows:
  - 2. The anchor devices to be set in concrete must be galvanized.

### 3.4 Expansion joints

- .1 The implementation of the expansion joints must be in compliance with the CAN/CSA-S6 standard and requirements of drawings with the following details :
  - .1 The longitudinal and transverse slopes of the concrete shoulders must correspond to the profiles provided for the pavement, on either side of the joint;
  - .2 The opening of the installed joint must be approved by the engineer.
  - 3. The joint must be positioned in the formworks and be securely attached, by means of spot welds, on the slab and backwall reinforcement or with the use of fixation rod;
  - 4. The angles or the temporary assembly plates have to be removed after the fixation of the joint.
- .2 No charges shall be imposed on new concrete elements before the resistance reaches 25 MPa.
- .3 The implementation of the joint seal is to be completed in one (1) single phase. The Contractor shall provide temporary measures to cover and protect the seal according to the phases of the work.

**3.5 Deck support**

- .1 The deck of the pedestrian bridge is to be supported before the replacement of the existing bearings.

**3.6 On-site Quality control**

- .1 Spot checks done by the manufacturer :
  - 1. Schedule site visits at the stages outlined below :
    - .1 Once the delivery and storage of the elements on site and the preparatory and other preliminary works are completed, but before the beginning of the installation work covered by this section;
    - .2 Once during the progress of work, that is to say once they are completed at 60%;
    - .3 Upon completion of work and after the cleaning.

**3.7 Cleaning**

- .1 Cleaning during the course of the works : clean in accordance with section « 01710 – Cleaning ». Leave the site clean at the end of each working day.
- .2 Final cleaning : once the work is completed, evacuate the surplus materials/equipment, wastes, tools and machinery in accordance with section « 01710 – Cleaning ».

**END OF SECTION**





## PART 1 - GENERAL

### 1.1 References

*(Current Editions)*

- .1 CGSB 1-GP-12c, Standard Paint colours.
- .2 CGSB 1-GP-48M, Primary Coat Paint, marine, on steel.
- .3 CAN/CGSB-1.59-M89, Outdoor Enamel Paint, glossy, alkyd resins.
- .4 CGSB 1-GP-61Ma, Marine Enamel Paint, exterior and interior, alkyd resins.
- .5 CAN/CGSB 1-93-92, Aluminum Enamel Paint.
- .6 CGSB 1-GP-171M, Mineral Zinc Coating.

### 1.2 Measurement for payment

- .1 Costs related to cleaning and painting of the existing steel elements are included in the prices of the item entitled « Cleaning and painting of steel » whose payment terms are described in section « 01290 - Measurement for payment ».

### 1.3 Samples

- .1 Submit samples required in accordance with the requirements of section « 01340 - Shop Drawings, Product and Sample Descriptions »
- .2 Upon request, the Engineer will provide a list of registered approved paint products.
- .3 The paintings that are not on the list of registered approved products must be approved by the Engineer before being used for purposes of these works. If it is proposed to use a non-approved paint, submit to the Engineer, for analysis and approval, two (2) sample of two (2) liters each, at least five (5) days before the beginning of the painting work. On the samples, indicate the project name, its location, the name and address of the manufacturer, the brand of paint, the paint code number assigned by the manufacturer and the number of the CGSB applicable standard.
- .4 Allow the Engineer to collect two (2) samples of two (2) liters of each type of paint delivered to the site; one sample must be taken from the original containers and the other in the painter's containers.

## PART 2 - PRODUCTS

### 2.1 Materials

- .1 The paint must be of the type indicated in the plans (2 layers, 250 microns total min.).
- .2 The topcoat must be green no. 35414, identified in the US FED-STD 595B standard « Colors Used in Government Procurement ».

## PART 3 - EXECUTION

### 3.1 Preparatory works

- .1 Shelter for works
  1. The Contractor shall provide a shelter for the cleaning and painting of the metal framing.
  2. The shelter must be leakproof and must prevent any escape of dust and residue outside the shelter. It must be designed to meet the structural capacity of the pedestrian bridge. Cleaning residues should be removed from the shelter prior to painting. The Contractor must provide a plan signed and sealed by an engineer member of the Ordre des Ingénieurs du Québec. This same engineer must inspect the shelter once completed and provide a signed and sealed certificate of conformity before the start of cleaning and painting
- .2 Metal surfaces to repaint
  - .1 Clean the metal surfaces for painting by removing the cracked, brittle, non-adhering or peeling paint, and any rust, rolling oxide, welding slag, dirt, oil, grease and other foreign substances using the following method and the standard listed below :
    - .1 Mechanical cleaning to bare metal : SSPC-SP-10 « Near white blast cleaning ».
  - .3 Do not apply paint until the prepared surfaces have been inspected and the work approved by the Engineer.
  - .4 Before undertaking the painting work, ensure that the degree of surface cleanliness is in accordance with the SSPC-Vis 1 standard.
  - .5 Surface protection

1. Protect surfaces that are not to be painted. If damaged, clean and refurbish as directed by the Engineer;
  2. Apply primer, finish coat or etching primer as soon as possible after the surfaces have been cleaned before they deteriorate;
  3. If rust stains appear on the prepared surfaces, clean them again;
  4. Prevent the clean surfaces to be contaminated with salts, acids, alkalis and other corrosive chemicals, with grease, oil and solvents, prior to the application of the primer coat and between subsequent layers of paint. If necessary, remove all traces of contamination immediately and apply the paint without delay;
  5. Protect from dust the cleaned and freshly painted surfaces, in a manner approved by the Engineer.
- .6 Mixing of the paint
1. Dilute the paint according to the manufacturer's instructions. If these instructions are not listed on the package, contact the manufacturer to obtain a written copy. Provide a copy of the instructions to the Engineer.

### 3.2 Paint application

- .1 Before applying the second coat of primer, caulk the joints between the contact surfaces of composed structural elements with a material approved by the Engineer.
- .2 Avoid applying the paint when :
  1. the temperature of the ambient air is below 5° C, or when it must go down to 0° C before the paint dries;
  2. the surface temperature exceeds 50° C, unless the paint is specifically formulated to be applied at high temperature;
  3. the site is bathed in fog or mist, or when it rains or snows, or when there is a risk of rain or snow, or when the relative humidity is above 85%;
  4. the surface to be painted is wet, humid or frosted;
  5. the previous coat is not completely dry.

- .7 Protect, shelter or heat paint surfaces and ambient air so as to satisfy the requirements for temperature and humidity formulated in section 3.2. Protect painted surfaces until the paint dries or until the weather conditions make such protection redundant.
- .8 Remove layers of paint that have been exposed to frost, excessive moisture, rain, snow or condensation. Prepare and paint the surfaces again.
- .9 Apply each layer of paint so as to form a continuous film of uniform thickness. Repaint surfaces where the paint layer is too thin as well as the exposed surfaces prior to applying the next coat of paint.
- .10 Painting on-site
  1. Paint the structural steel elements as soon as possible after the cleaning;
  2. If concrete work or other work damages the paint, clean and repaint the affected areas. Before applying the paint, remove burrs and streaks of concrete;
  3. If the paint does not meet the requirements of the specifications and if the Engineer requires so, remove any defective paint, clean surfaces thoroughly and repaint them in accordance with the requirements of this section.
- .11 Treatment of metallic painted elements
  1. Scrape the surfaces damaged during the work, and retouch using the same number of layers of the same types of paint applied initially.

**END OF SECTION**

**ANNEXE I –  
COMPLEMENTARY DOCUMENTS**

---





**Sandwell**

TEL QUE CONSTRUIT 01/14/98  
 AS BUILT  
 2 EMS / ISSUED 12/9/98  
 1 EMS / ISSUED 31/7/98

Modification Date  
 A. No du detail A. Detail No  
 B. Localisation B. Localisation  
 C. Sur feuille No C. On sheet No

CONCEPTION: DESIGNED BY:  
 H. NERDJIVANIAN  
 Dessiné par: DRAWN BY:  
 H. NERDJIVANIAN  
 Vérifié par: CHECKED BY:  
 G. HENRI/S. ACIMOVIC  
 Charge de projet: JOB CAPTAIN BY:  
 H. BERCOVICI  
 VALIDÉ PAR: VALIDATED BY:

Charge de projet: Project manager:  
 LUCIE HOUDE  
 Directeur de projet: Project director:  
 RICHARD LAROCHE

Project:  
 BASSIN 3  
 CANAL LACHINE  
 PASSERELLE  
 GEORGE ETIENNE CARTIER  
 FOOTBRIDGE  
 BASIN 3  
 CANAL LACHINE

Titre du dessin: Drawing title:  
 IMPLANTATION  
 SITING

Date: 1998-07-31  
 Feuille: 2 / 7

Echelle: IND./SHOWN  
 Ref. Consultant: 0000

No. de référence: Reference no.  
 168/00/PR.1-172

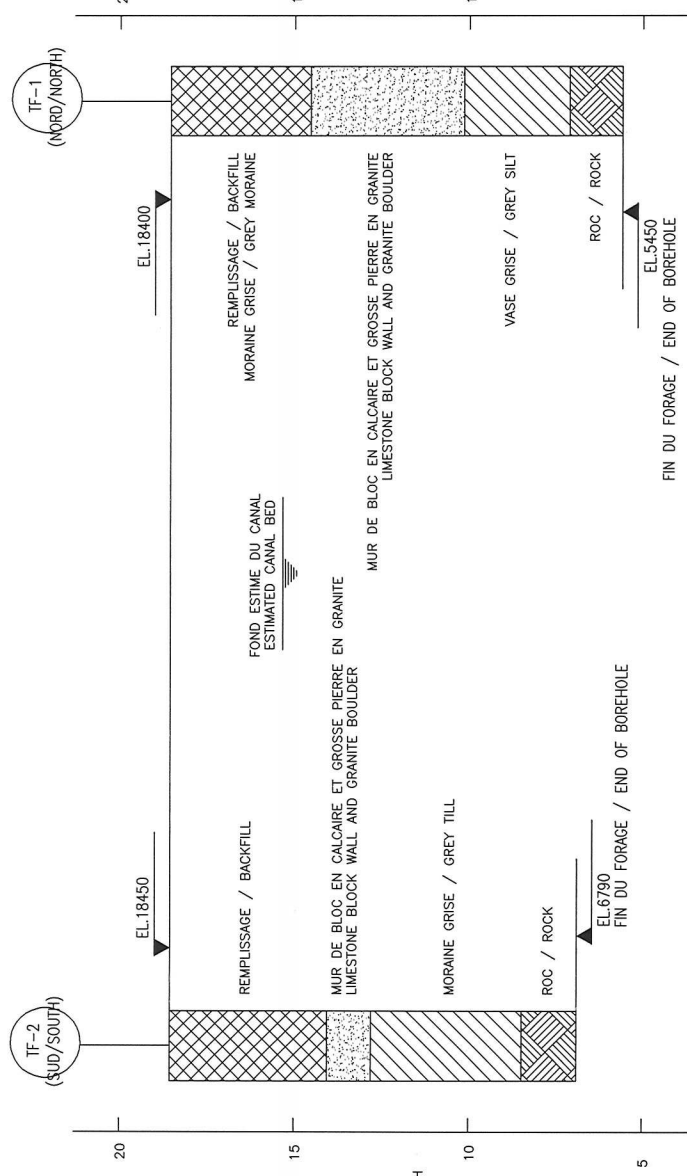

FORAGES / BORINGS  
 VOIR / SEE NOTE 4

**NOTES GÉNÉRALES:**  
 1. L'ENTREPRENEUR DEVRA VISITER LES LIEUX ET S'Y FAMILIARISER COMPLÈTEMENT AVANT DE SOUMISSIIONNER.  
 2. L'ENTREPRENEUR EST TENU DE PRENDRE ET VÉRIFIER TOUTES LES DIMENSIONS AU CHANTIER AVANT DE COMMENCER TOUT TRAVAIL.  
 3. TOUS LES TRAVAUX DOIVENT ÊTRE CONFORMES AUX NORMES DE L'ACNOR (DERNIÈRE ÉDITION)  
 4. POUR LOCALISATION DES TROUS DE FORAGES ET PROFILS VOIR RAPPORT D'ÉTUDE GÉOTECHNIQUE PAR JOURNEUX, BEDARD & ASSOC. INC.  
**GENERAL NOTES:**  
 1. THE CONTRACTOR MUST VISIT THE SITE AND GET FULLY ACQUAINTED WITH IT BEFORE SUBMITTING HIS BID.  
 2. THE CONTRACTOR MUST TAKE AND VERIFY ALL DIMENSIONS ON THE SITE BEFORE BEGINNING THE WORK.  
 3. ALL WORKS TO FOLLOW CSA (LAST EDITION)  
 4. FOR BOREHOLE LOCATION AND PROFILES SEE GEOTECHNICAL STUDY REPORT BY JOURNEUX, BEDARD & ASSOC. INC

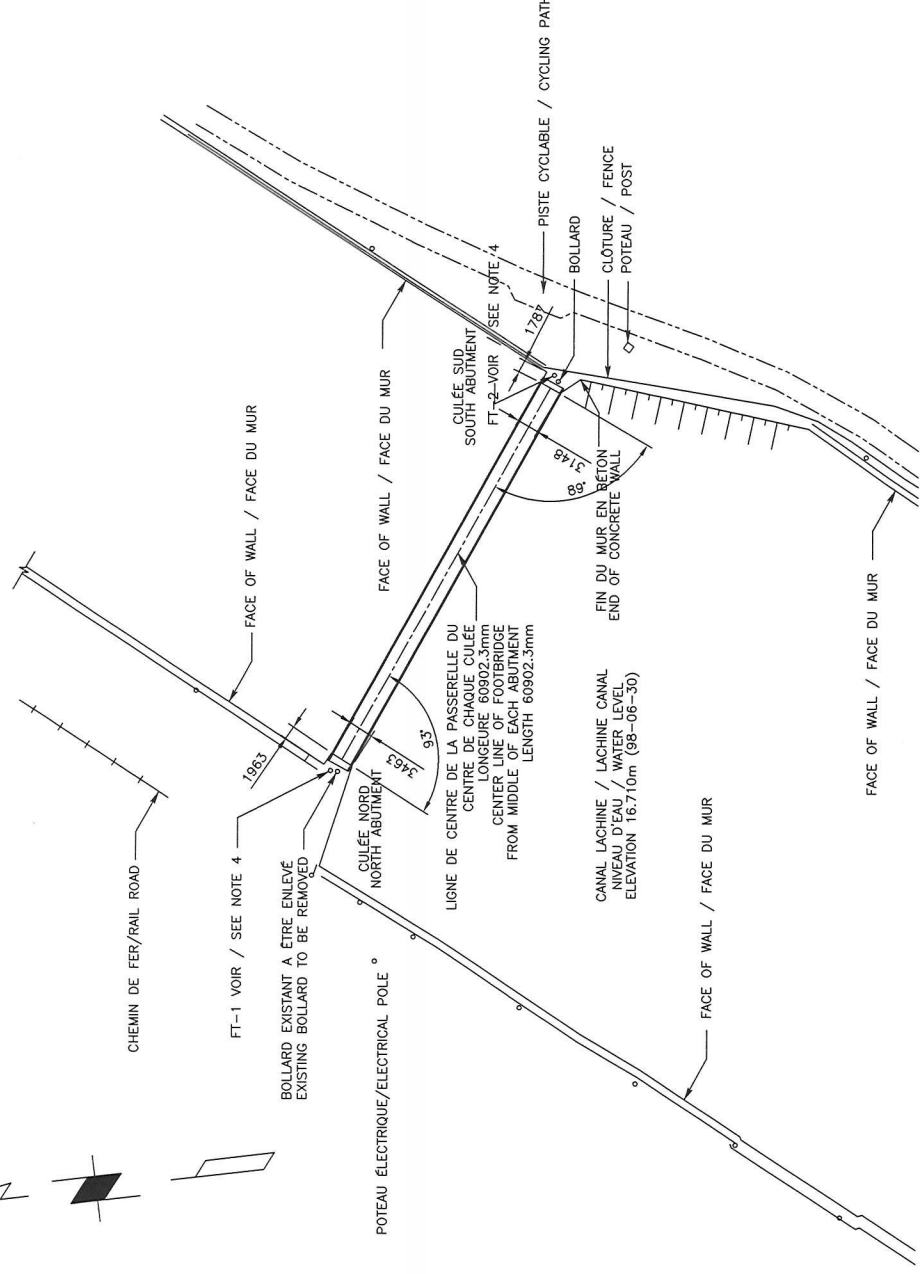

PLAN  
 1:500

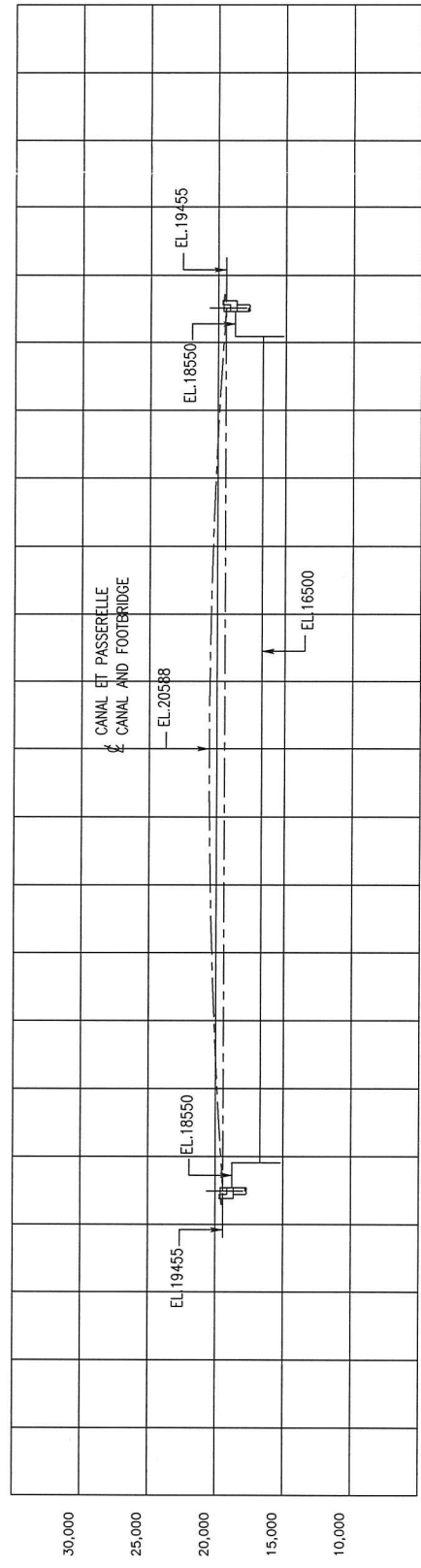

PROFILE  
 1:250







**Sandwell**

DESIGN: 01/4/98  
 AS BUILT: 12/6/98  
 EMIS / ISSUED: 31/7/98

Modification	Date
A. No du détail	A. Detail No
B. Localisation	B. Localisation
C. Sur feuille No	C. On sheet No

CONCEPTION:	DESIGN:
Conçu par: H. NERDJUVANIAN	Designed by: H. NERDJUVANIAN
Dessiné par: H. NERDJUVANIAN	Drawn by: H. NERDJUVANIAN
Vérifié par: G. HENRI/S. SACIMOVIC	Checked by: G. HENRI/S. SACIMOVIC
Charge de projet: H. BERCOVICI	Job captain by: H. BERCOVICI
VALIDÉ PAR:	VALIDATED BY:

Charge de projet: LUCIE HOUDE  
 Project manager: LUCIE HOUDE  
 Directeur de projet: RICHARD LAROCHE  
 Project director: RICHARD LAROCHE

Project: BASSIN 3  
 CANAL LACHINE  
 PASSERELLE  
 GEORGE ETIENNE CARTIER  
 FOOTBRIDGE  
 BASIN 3  
 CANAL LACHINE

Titre du dessin: PLAN D'ENSEMBLE  
 LAYOUT PLAN  
 Date: 1998-07-31  
 Feuille: 3 / 7  
 Echelle: IND./SHOWN  
 Ref. Consultant: 0000  
 No de référence: 168/00/PR.1-172  
 Ministère:

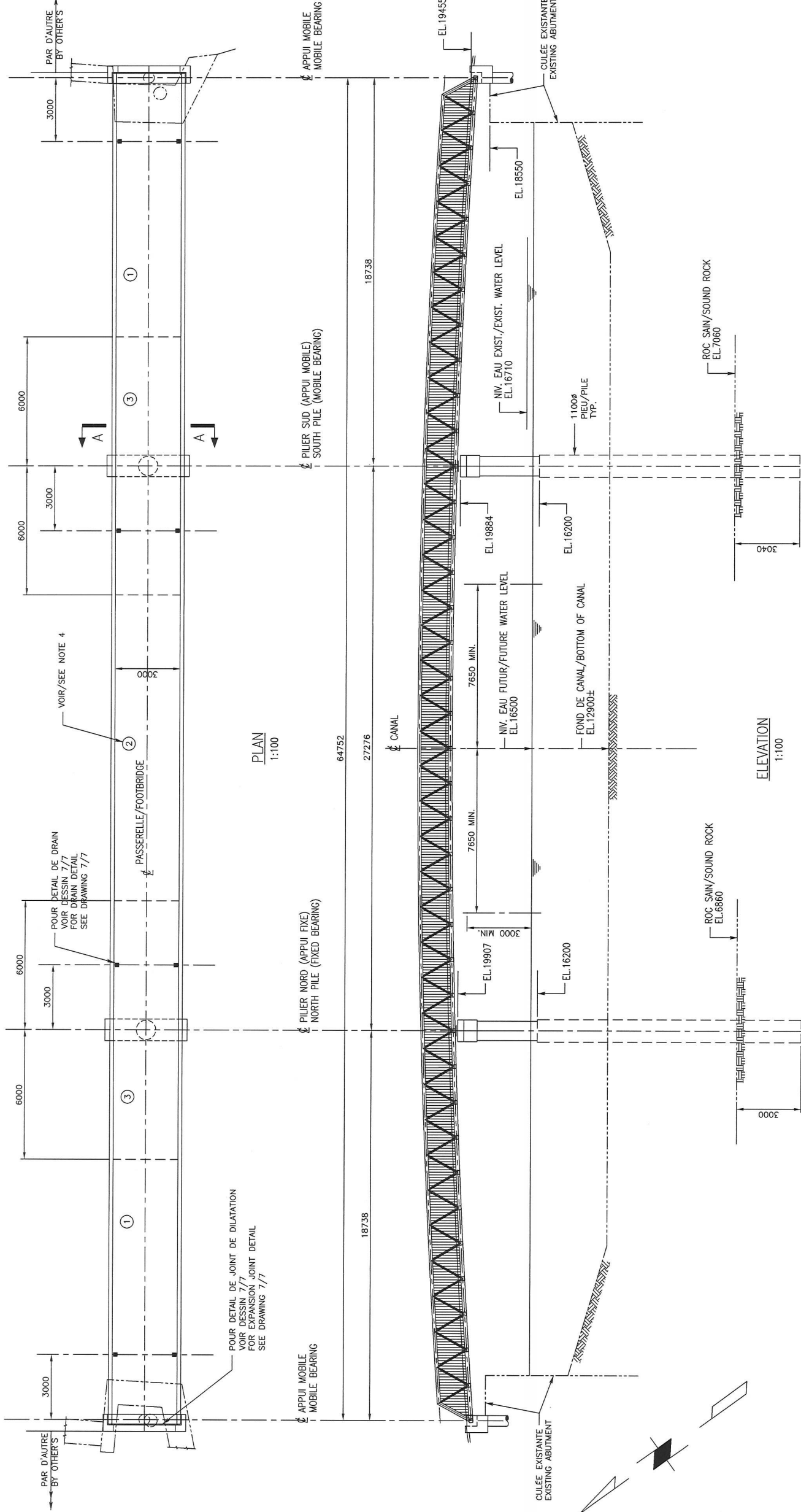

**SURCHARGES/LIVE LOADS:**  
 CHARGE CONCENTRÉE/POINT LOAD: 54KN  
 CHARGE UNIFORME/UNIFORM DISTRIBUTED LOAD: 5.0KN/M<sup>2</sup>

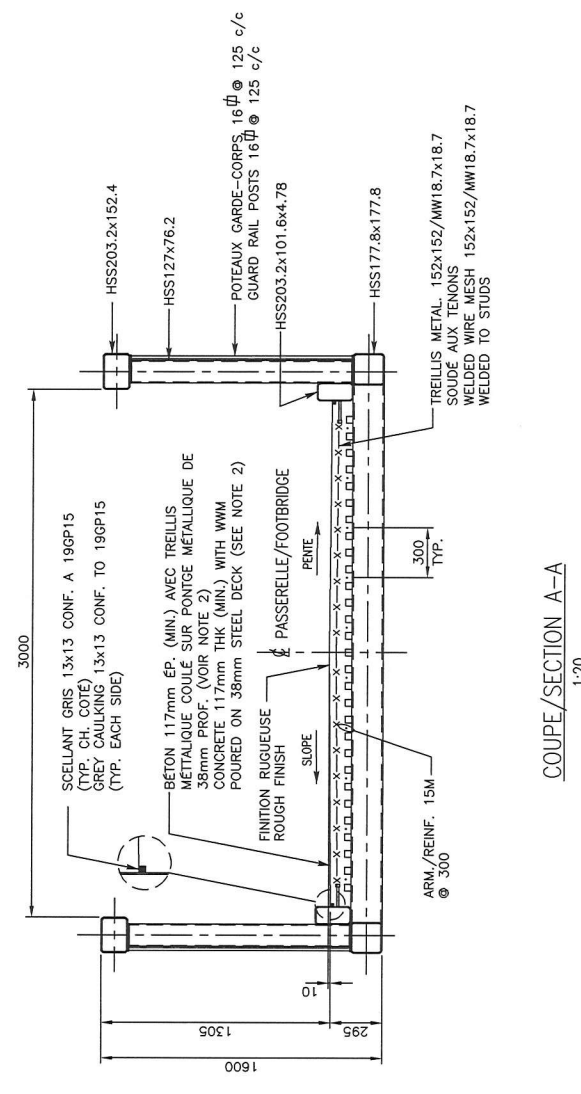

- NOTES:**
- ACIER DE CHARPENTE:
    - TOUT L'ACIER DEVA ÉTRE CONFORME AUX NORMES ACNOR G40.21M NUANCE 350W
    - LA SOUDURE DEVA ÉTRE CONFORME AUX NORMES ACNOR W-59.1
    - TOUT L'ACIER DEVA ÉTRE NETTOYÉ, PUIS DEVA ÉTRE PEINT EN USINE (VOIR DEVIS)
  - PONTAGE D'ACIER:
    - TOUT L'ACIER DEVA ÉTRE NETTOYÉ, PUIS DEVA ÉTRE PEINT EN USINE (VOIR DEVIS)
    - LA FABRICATION ET LE MONTAGE DEVRONT ÉTRE CONFORMES A LA NORME ACNOR S6.
  - BÉTONNAGE DU TABLIER (SEQUENCES):
    - LES OPÉRATIONS 1-2 DOIVENT ÉTRE FAITES EN ORDRE SANS INTERVALLES DÉFINIS ET IL DOIT Y AVOIR UN INTERVALLE DE 2 JOURS OU PLUS ENTRE CES DERNIÈRES ET L'OPÉRATION 3
  - STRUCTURAL STEEL:
    - ALL STEEL MUST BE NEW AND ACCORDING CSA G40.21M GRADE 350W WELDING CONFORM TO CSA W59.1.
    - ALL STEEL MUST BE PAINTED IN SHOP (SEE SPECIFICATION).
  - STEEL DECK:
    - TYPE HB 938 INV. 0.76mm THICKNESS, GALVANIZED, BY VIC-WEST OR APPROVED EQUAL
    - FABRICATION AND ERECTION ACCORDING TO CSA S6.
    - DECK CONCRETING SEQUENCE:
      - STEPS 1-2 MUST BE DONE IN ORDER WITH DEFINITE INTERVALS AND IT MUST HAVE AN INTERVAL OF 2 DAYS OR MORE BETWEEN STEPS 1-2 AND STEP 3.

**COUPE/SECTION A-A 1:20**





**Sandwell**

DESIGNER OF RECORD FOR THE WORKS SHOWN ON THIS DRAWING. THE DESIGNER IS NOT RESPONSIBLE FOR THE WORKS SHOWN ON THIS DRAWING IF THE WORKS ARE NOT CONSTRUCTED IN ACCORDANCE WITH THE DESIGN AND SPECIFICATIONS SHOWN ON THIS DRAWING. THE DESIGNER IS NOT RESPONSIBLE FOR THE WORKS SHOWN ON THIS DRAWING IF THE WORKS ARE NOT CONSTRUCTED IN ACCORDANCE WITH THE DESIGN AND SPECIFICATIONS SHOWN ON THIS DRAWING.

Modification	TEL QUE CONSTRUIT AS BUILT	01/4/98
3	EMIS / ISSUED	12/8/98
2	EMIS / ISSUED	31/7/98
1	EMIS / ISSUED	

A. No du detail  
B. Localisation  
C. Sur feuille No

DESIGN: H. NERDJUVANIAN  
Drawn by: H. NERDJUVANIAN  
Checked by: G. HENRI/S. ACIMOVIC  
Job captain by: H. BERCOVICI  
VALIDATED BY:

Project manager: LUCIE HOUDE  
Project director: RICHARD LAROUCHE

Project: BASSIN 3  
CANAL LACHINE  
PASSERELLE  
GEORGE ETIENNE CARTIER  
FOOTBRIDGE

Basin 3  
CANAL LACHINE

APPAREILS D'APPUI  
ET PILE  
BEARING PADS  
AND PILE

Date: 1998-07-31  
Echelle: IND./SHOWN  
Ref. Consultant: 0000  
No. de reference: 168/00/PR.1-172

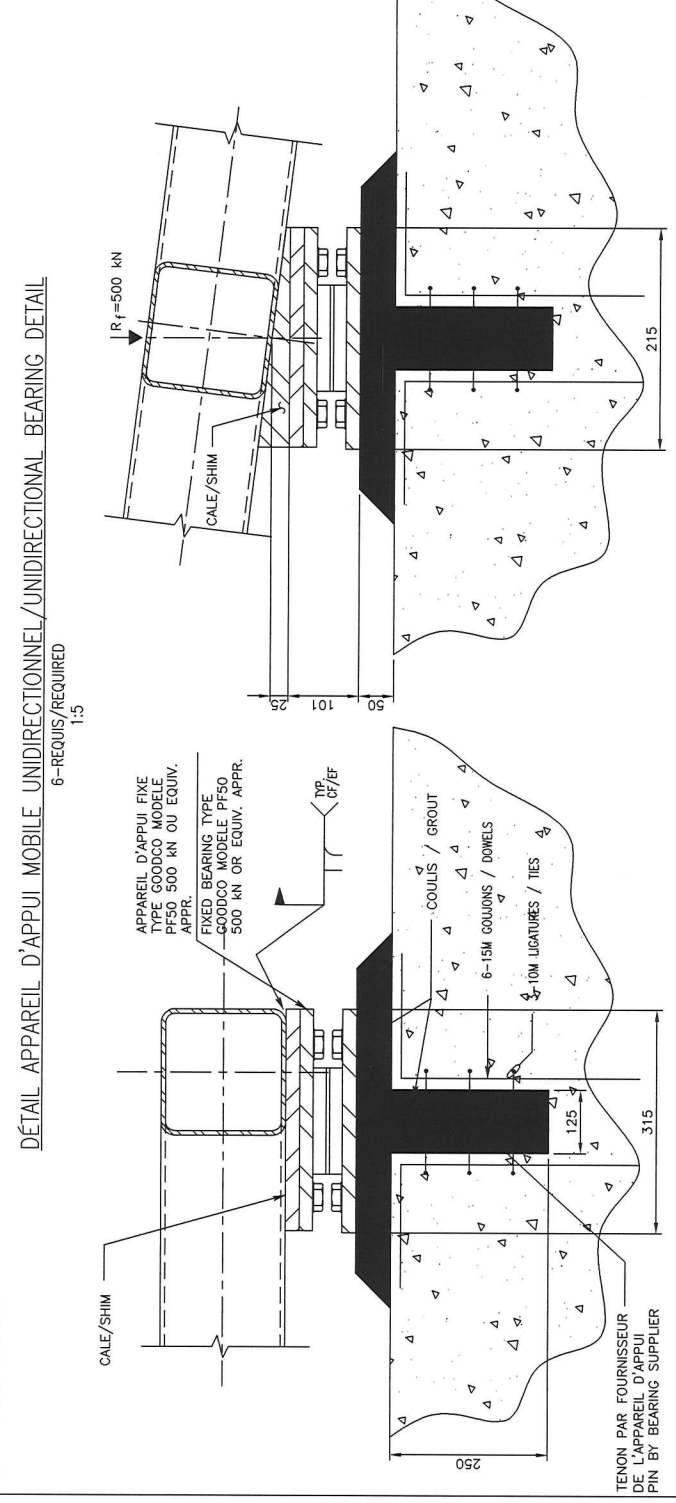
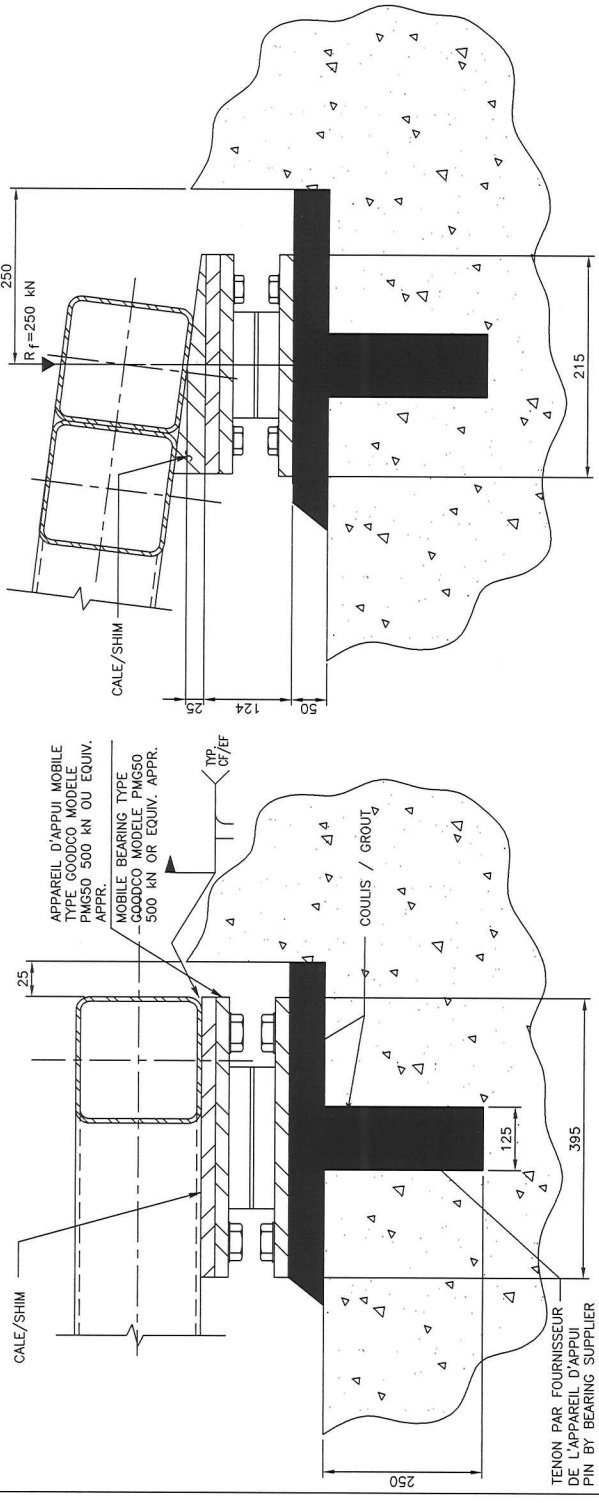
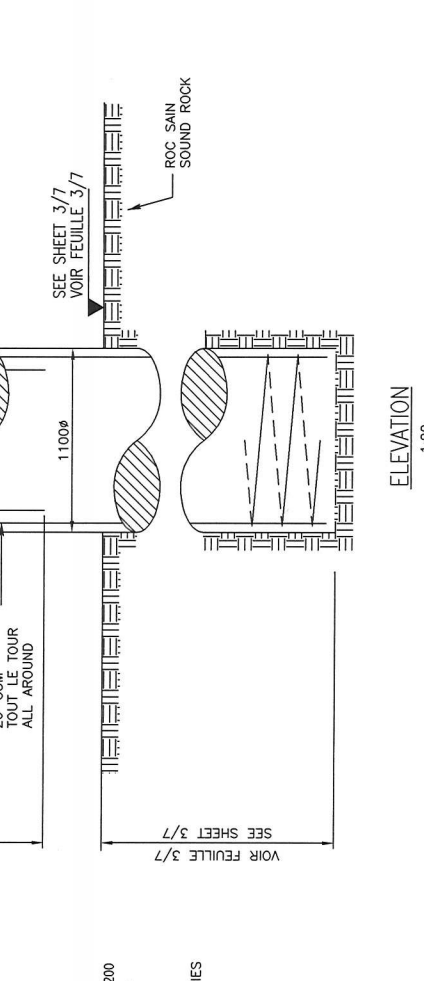
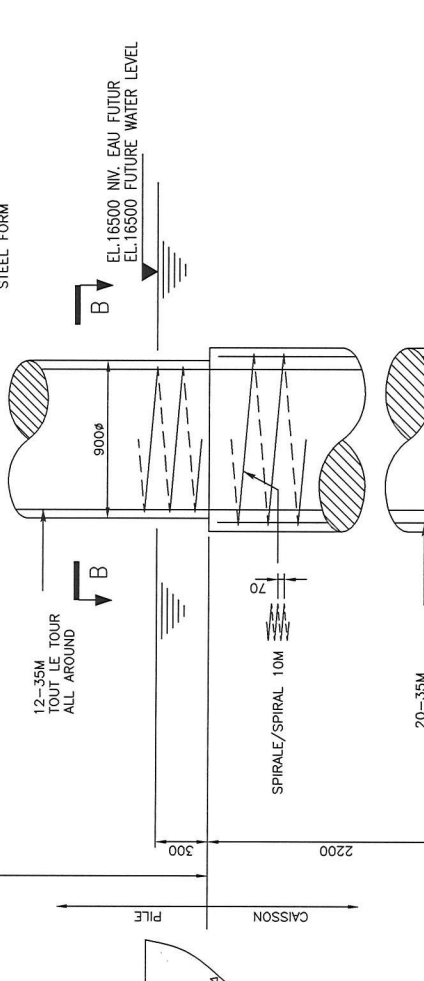
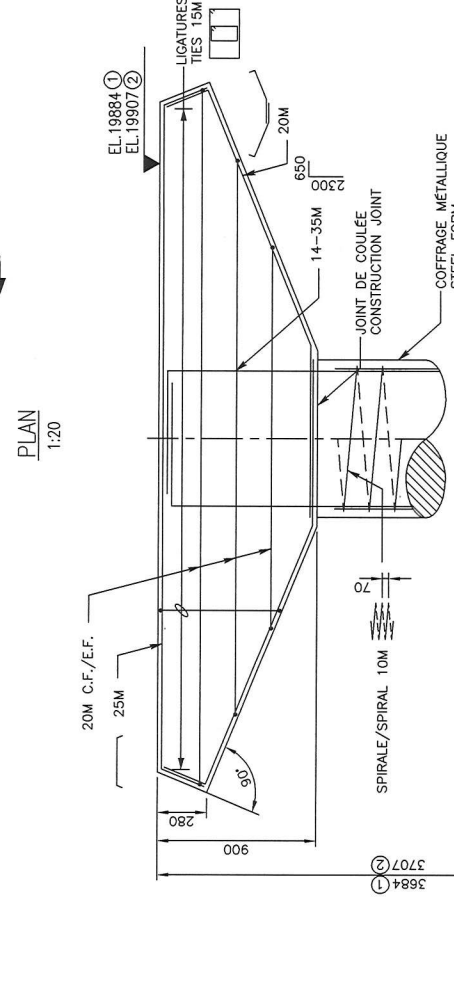
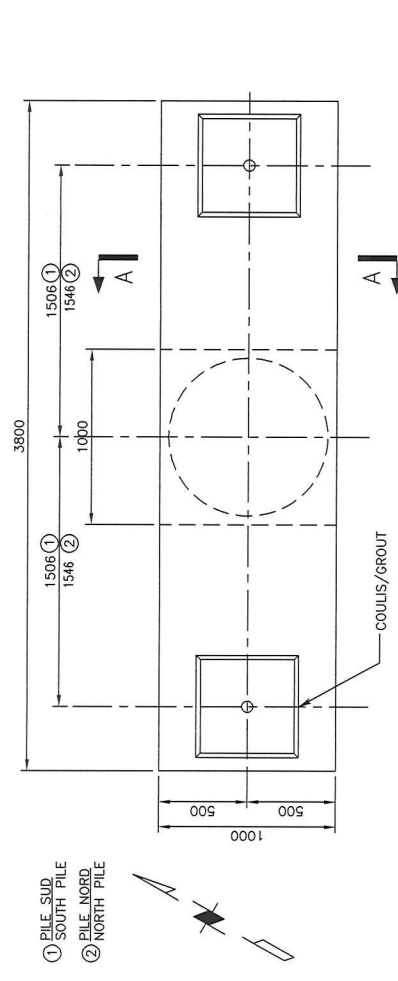

**NOTES:**

- BÉTON: 30 MPa A 28 JOURS (DAILES, CULÉES)  
35 MPa A 28 JOURS (PILES ET CHEVETRES)
- ARMATURE: NUANCE 400 CONFORME A ACNOR G30.12M  
TREILLIS METALLIQUE CONFORME A ACNOR G30.5  
ARMATURES AUX PAROIS DES COFFRAGES DOIT ETRE:
- SAUF INDICATIONS CONTRAIRES AUX PLANS, LA DISTANCE DES  
BÉTON EXPOSE A L'EAU OU COULE CONTRE LE SOL 75MM  
BÉTON EN CONTACT AVEC LE SOL APRES DECOFFRAGE OU EXPOSE  
AUX INTERMÉDIAIRES 50MM

**NOTES:**

- CONCRETE: 30 MPa AT 28 DAYS (SLABS, ABUTMENTS)  
35 MPa AT 28 DAYS (PILES AND HEADERS)
- REINFORCING: GRADE 400 CONFORM TO CSA G30.12M  
WELDED WIRE FABRIC CONFORM TO CSA G30.5
- UNLESS INDICATED OTHERWISE ON DRAWINGS, CONCRETE PROTECTION  
CONCRETE EXPOSED TO WATER OR CASTED AGAINST EARTH 75MM  
CONCRETE IN CONTACT WITH THE GROUND OR EXPOSED  
TO WEATHER 50MM

**APPAREILS D'APPUI:**

- MATERIAUX: SAUF INDICATIONS CONTRAIRES, ACIER CONFORME A  
ACNOR G40.21M, NUANCE 350M.
- COULIS: MORTIER SANS RETRAIT NON-METALLIQUE D'UNE RESISTANCE  
MINIMUM DE 30 MPa.
- L'INSTALLATION DES APPAREILS D'APPUI DOIVENT SE FAIRE SOUS LA  
SURVEILLANCE DE L'ENTREPRENEUR EN CHARPENTE METALLIQUE.  
BEARING PADS:
- MATERIALS: UNLESS INDICATED OTHERWISE STEEL CONFORM TO  
ACNOR G40.21M, GRADE 350M.
- GROUT: NON-SHRINK AND NON-METALLIC GROUT WITH A  
MINIMUM OF 30 MPa.
- INSTALLATION OF BEARING PADS MUST BE DONE UNDER  
STRUCTURAL STEEL CONTRACTOR SUPERVISION.





**Sandwell**

SEUL LE PROPRIÉTAIRE EST RESPONSABLE DE LA CONSTRUCTION DE LA STRUCTURE. LE PROPRIÉTAIRE EST RESPONSABLE DE LA CONSTRUCTION DE LA STRUCTURE. LE PROPRIÉTAIRE EST RESPONSABLE DE LA CONSTRUCTION DE LA STRUCTURE.

3	TEL. QUE CONSTRUIT AS BUILT	01/14/98
2	EMIS / ISSUED	12/28/98
1	EMIS / ISSUED	31/7/98
Modification		Date

A. No du détail  
B. Localisation  
C. Sur feuille No



A. Detail No  
B. Localisation  
C. On sheet No

CONCEPTION: DESIGNED:  
Conçu par: H. NERDJUVANIAN  
Dessiné par: H. NERDJUVANIAN  
Vérifié par: G. HENRI/S. ACIMOVIC  
Charge de projet: H. BERCOVICI  
Job captain by:  
VALIDATED BY:

Charge de projet: LUCIE HOUIDE  
Project manager:  
Directeur de projet: RICHARD LAROCHE  
Project director:  
Project: BASSIN 3  
CANAL LACHINE  
PASSERELLE  
GEORGE ETIENNE CARTIER  
FOOTBRIDGE  
BASIN 3  
CANAL LACHINE

Date: 1998-07-31  
Feuille: 7/7  
Echelle: IND./SHOWN  
Scale:  
Ref. Consultant: 0000  
Ref. Consultant:

Titre du dessin: DÉTAILS  
Drawing title: DETAILS  
No. de référence: 168/00/PR.1-172  
Reference no. Ministry:

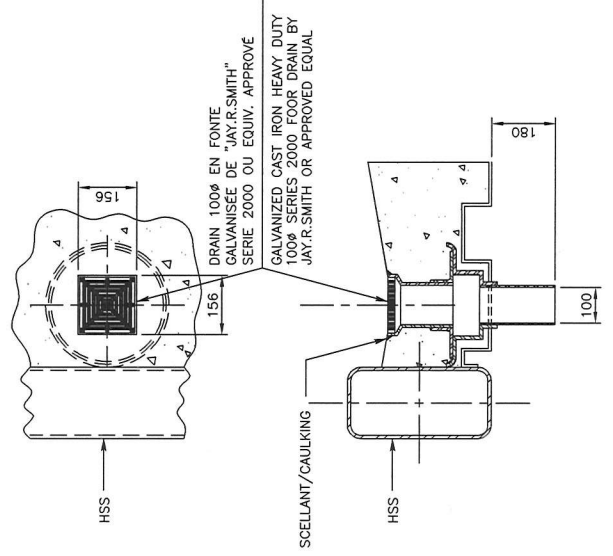
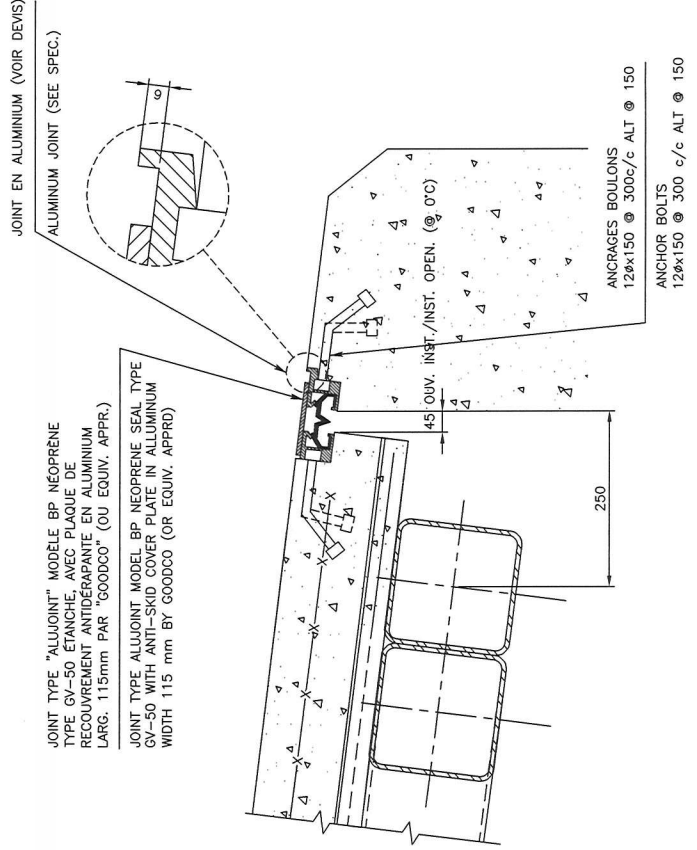
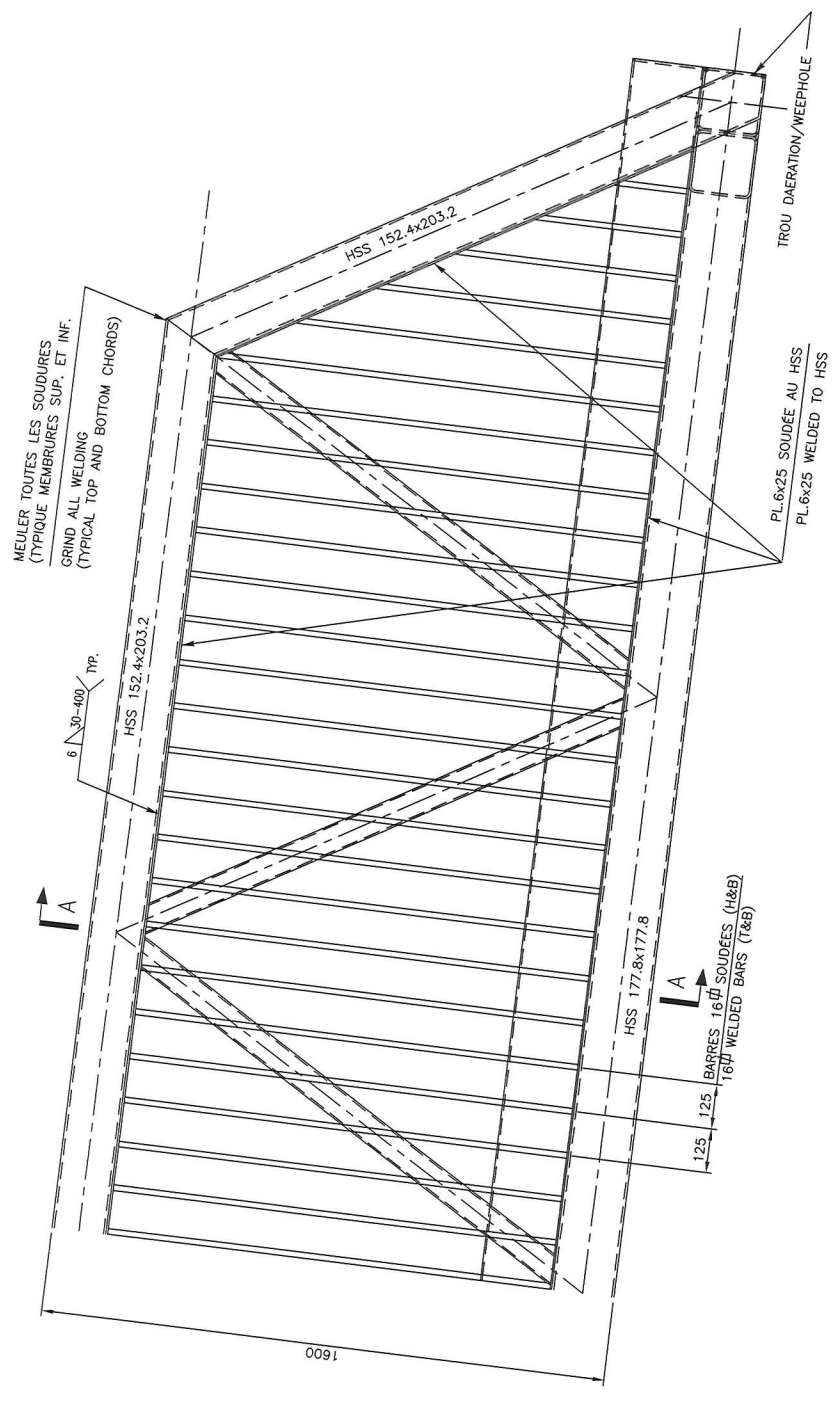
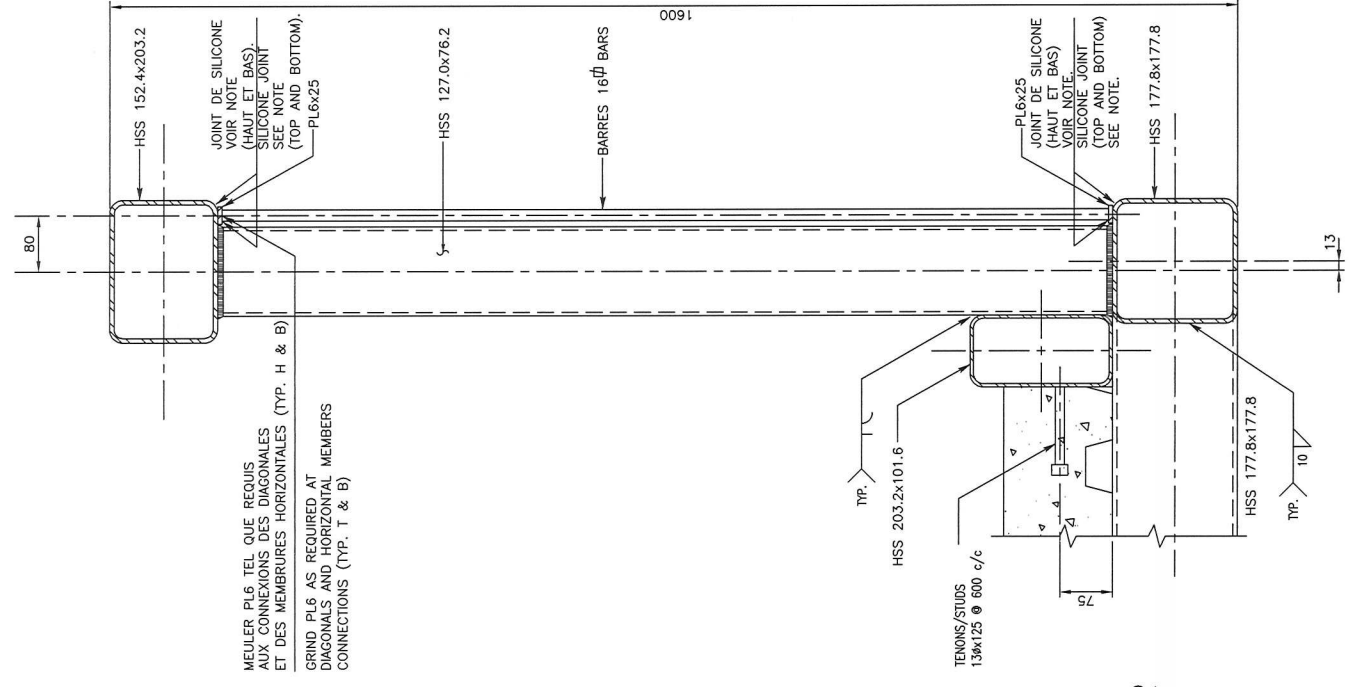







**Sandwell**

TEL QUE CONSTRUIT  
AS BUILT  
EMIS / ISSUED  
EMIS / ISSUED

01/11/98  
12/18/98  
31/7/98

Modification  
Date

A. No du detail  
B. Localisation  
C. Sur feuille No

A. Detail No  
B. Localisation  
C. On sheet No

CONCEPTION:  
Conçu par:  
H. NERDJUVANIAN

DESIGN:  
Designed by:  
H. NERDJUVANIAN

Dessiné par:  
H. NERDJUVANIAN

Vérifié par:  
G. HENRI / S. ACIMOVIC

Charge de projet:  
Job captain by:  
H. BERCOVICI

VALIDÉ PAR:  
VALIDATED BY:

Charge de projet :  
Project manager:  
LUCIE HOUDE

Directeur de projet :  
Project director:  
RICHARD LAROCHE

Projet:  
Project:  
BASSIN 3  
CANAL LACHINE  
PASSERELLE  
GEORGE ETIENNE CARTIER  
FOOTBRIDGE  
BASIN 3  
CANAL LACHINE

Titre du dessin:  
Drawing title:  
APPUI NORD ET SUD  
NORTH & SOUTH SUPPORTS

Date:  
1998-07-31

Echelle:  
Scale:  
IND./SHOWN

Ref. Consultant:  
0000

No de référence:  
Reference no:  
168/00/PR.1-172

Feuille:  
5 / 7

Sheet:  
5 / 7

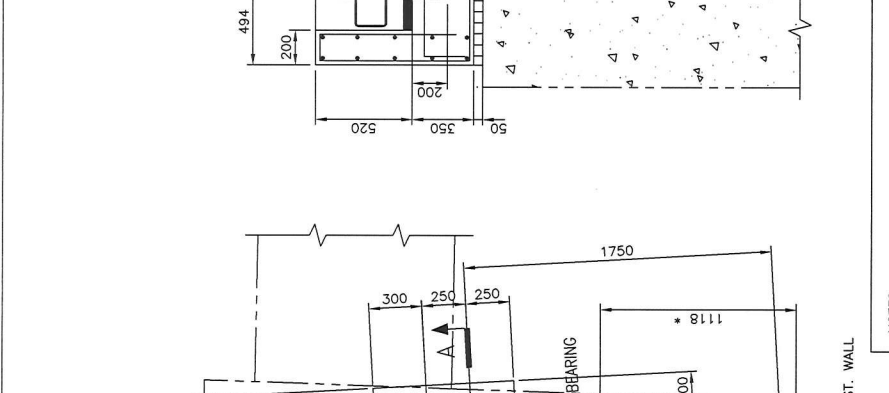
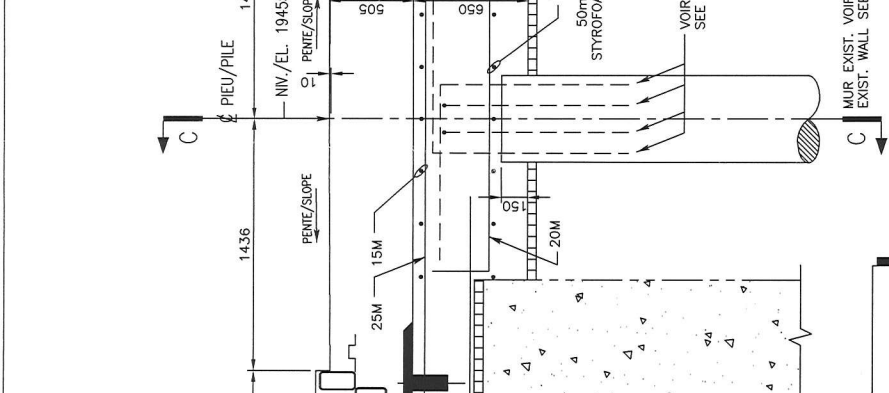
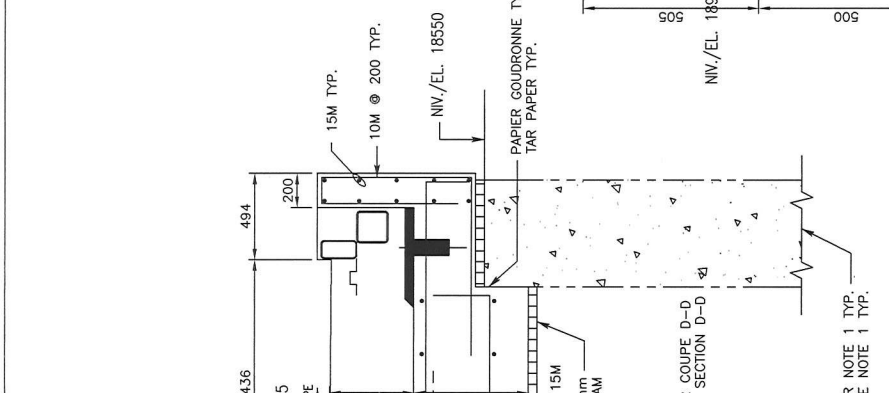
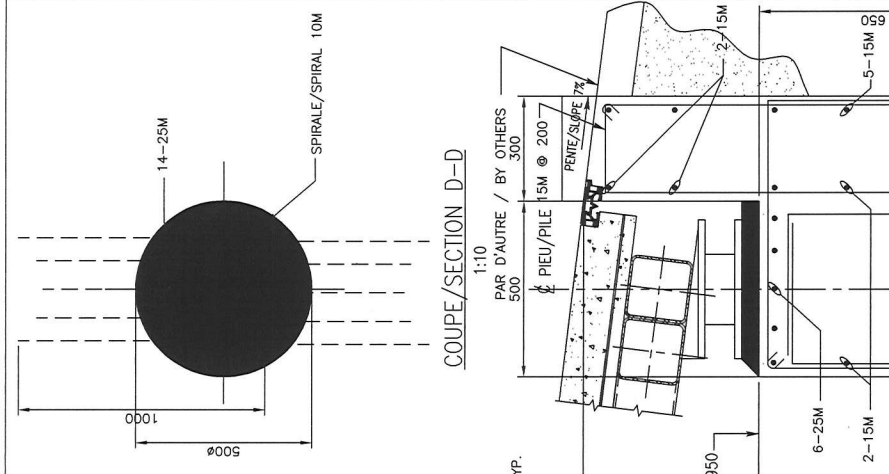

NOTES:

- LA FINITION DES MURS EXISTANTS PAR D'AUTRES.
- LES DIMENSIONS MARQUEES AINSI (\*) DOIVENT ETRE VERIFIEES AU CHANTIER AVANT LE DEBUT DES TRAVAUX.
- EXISTING CONCRETE WALL RESURFACING BY OTHERS.
- ALL DIMENSIONS MARKED THUS (\*) SHALL BE CONFIRMED IN FIELD PRIOR OF THE COMMENCEMENT OF THE WORK.

